

GPIB Command Syntax
for

E1962B cdma2000 Mobile Test Application Revision B.02

1000-1808



Agilent Technologies

Contents

Diagram Conventions	7
Description	7
ABORT	9
AFGenerator	9
CALibration	10
CALL:ACC	10
CALL[:CELL]:APARameter	11
CALL:AVCTest	11
CALL:AWGNoise:POWer	12
CALL:BAND	12
CALL:CHANnel	13
CALL[:CELL]:CLPControl	13
CALL:CONNected[:STATe]	14
CALL[:CELL]:CONTRol:DOWNlink:FREQuency:AUTO	14
CALL:D2KTest	14
CALL:DCONnected[:STATe]	15
CALL:END	15
CALL[:CELL]:ESCAPE[:MODE]	15
CALL:FCHannel	16
CALL:FM	16
CALL:HANDoff	17
CALL[:CELL]:MCCode	17
CALL[:CELL]:MNCCode	17
CALL:MS:ANALog	17
CALL:MS:REPorted:<BCL,BWT>	17
CALL:MS:REPorted:CAPability:CCHannel:DEDicated	18
CALL:MS:REPorted:CAPability:FCHannel	18
CALL:MS:REPorted:CAPability:QUERy	18
CALL:MS:REPorted:CAPability:SCHannel:FORWard	19
CALL:MS:REPorted:CAPability:SCHannel:REVerse	20
CALL:MS:REPorted:CLEar	20
CALL:MS:REPorted:CPLass	20
CALL:MS:REPorted:CTXType	20
CALL:MS:REPorted:DUAL[:MODE]	21
CALL:MS:REPorted:<EIRP,ESN>	21
CALL:MS:REPorted:<MCC,MIN1,MIN2,MNC,MSIN>	21
CALL:MS:REPorted:<ONUM,... OPER,PCL,PCON,PNUM,PREV,QPCH>	21
CALL:MS:REPorted:<RCON,REG,REV,SCIN,SCL,TXT>	22
CALL[:CELL]:NIDentity	22
CALL:OCNSource	22
CALL[:CELL]:OPERating	23
CALL:ORIGinate	23

Contents

CALL:ORIGinate	23
CALL:PAGing	24
CALL:PILot	25
CALL[:CELL]:PNOFset	25
CALL[:CELL]:POWer	26
CALL[:CELL]:PROTocol	27
CALL:QPCHannel	28
CALL[:CELL]:RCONfig	28
CALL:REGister	29
CALL[:CELL]:RFGenerator	29
CALL[:CELL]:RLGain	29
CALL:SCHannel	30
CALL:SETup:AVC	31
CALL:SETup:BAND	31
CALL:SETup:CHANnel	31
CALL:SETup:HANDoff	31
CALL:SETup:MS:ANALog	32
CALL:SETup:SYSTem	32
CALL[:CELL]:SIDentity	32
CALL[:CELL]:SOPTION	33
CALL:STATus	34
CALL:SYNC	38
CALL[:CELL]:SYSTem	38
CALL:TOTal:POWer	39
CALL:TRAFfic	39
CALL:TRIGger:TYPE	40
DISPlay	40
FETCh:AFANalyzer	41
FETCh:ATXPower	43
FETCh:CAPPower	43
FETCh:CCTPhase	44
FETCh:CFERror	44
FETCh:CPOWer	45
FETCh:CTXSpurious	45
FETCh:DAPower	45
FETCh:FM	46
FETCh:FSTability	47
FETCh:GPOWer	48
FETCh:HWQuality	48
FETCh:SAUDio	49
FETCh:TFERror	50
FETCh:WQQuality	51

Contents

INITiate	53
READ	55
RFANalyzer	57
SETup:AFANalyzer	59
SETup[:ALL]:CONTinuous	60
SETup:ATXPower	60
SETup:CAPPower	61
SETup:CCTPhase	62
SETup:CFERror	63
SETup:CPOWER	64
SETup:CTXSpurious	65
SETup:DAPower	66
SETup:FM	67
SETup:FSTability	69
SETup:GPOWER	70
SETup:HWQuality	70
SETup:SAUDio	71
SETup:TFERror	72
SETup:WQuality	73
STATus:OPERation:	74
STATus:PRESet	80
STATus:QUEStionable	80
Status Byte Register	86
Standard Event Status Register	87
SYSTem:APPLication	90
SYSTem:BEEPer	90
SYSTem:CONFIgure:INFORMATION:HARDware:VERBoSe?	90
SYSTem:COMMunicate	91
SYSTem:CORRection	91
SYSTem:CURREnt:TA	92
SYSTem:ERRor?	92
SYSTem:MEASurement:RESet	92
SYSTem:PRESet	92
SYSTem:ROSCillator	92
SYSTem:SYNChronized	92
IEEE 488.2 Common Commands	93

Contents

Diagram Conventions

Description

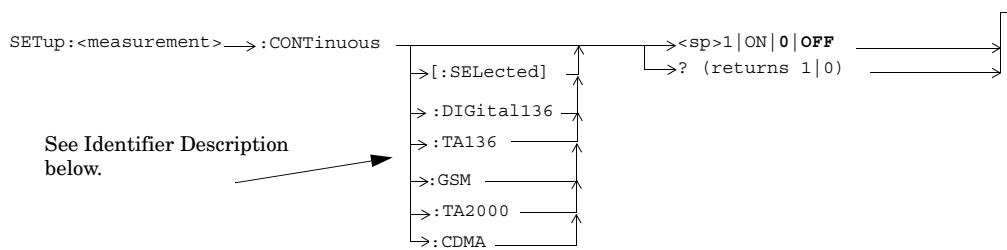
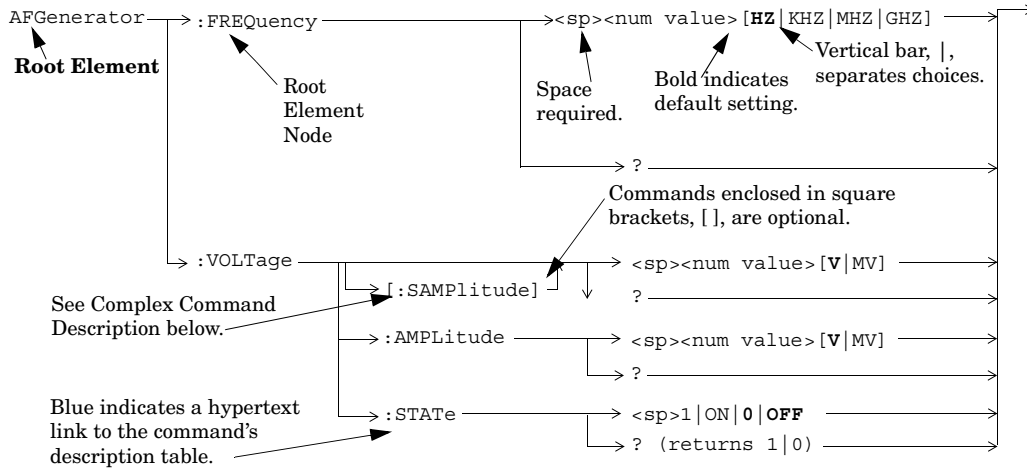

Diagram Description

Statement elements are connected by lines. Each line can be followed in only one direction, as indicated by the arrow at the end of the line. Any combination of statement elements that can be generated by starting at the **Root Element** and following the line the **direction of the arrow** is syntactically correct. The drawings show the proper use of spaces. Where spaces are required they are indicated by **<sp>**, otherwise no spaces are allowed between statement elements.

Diagram Conventions

Complex Command Description

A complex command sets the state of the parameter to ON, and is used to set a value for that parameter. These parameters; amplitude, frequency, gain, number, time, and value can be used as a complex command. Refer to the specific command for the parameter that applies.

Identifier Description

Some test applications are able to test more than one radio format. There may be commands/queries that are shared by more than one radio format in the some of these test applications. Identifiers are used to specify the radio format for the command/query. The command/query is sent to the active radio format if you don't use an identifier. An identifier must be used when sending commands to the inactive radio format.

Developing Code

It is recommended that you set the Test Set's operating environment to debug. To set the Test Set debug mode to "ON" use the following syntax:

```
SYSTem:COMMunicate:GPiB:DEBUg ON
```

Units-of-Measure

Amplitude (linear)	V
Frequency	Hz
Power (logarithmic)	dBm
Time	s

ABORt

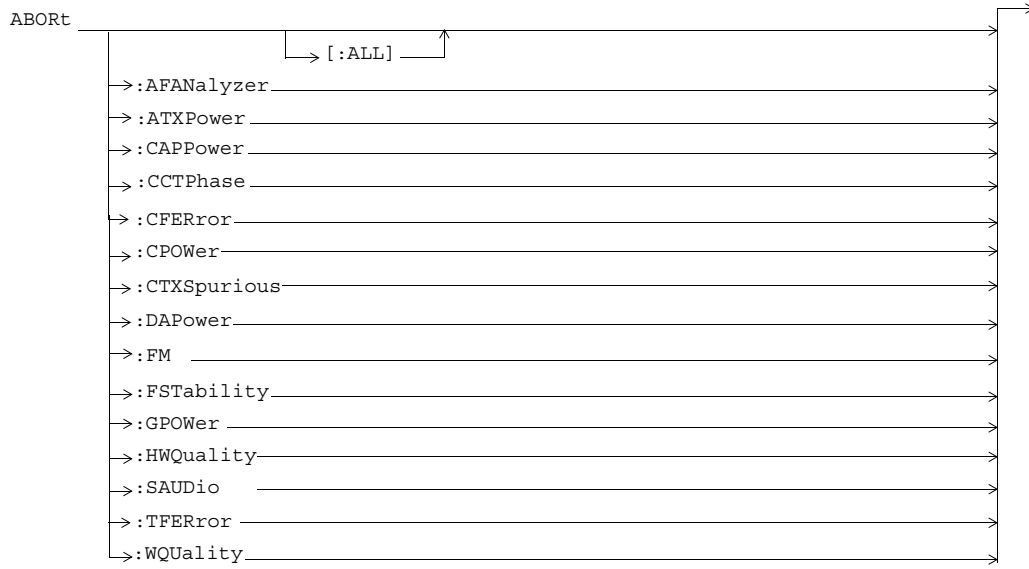

AFGenerator

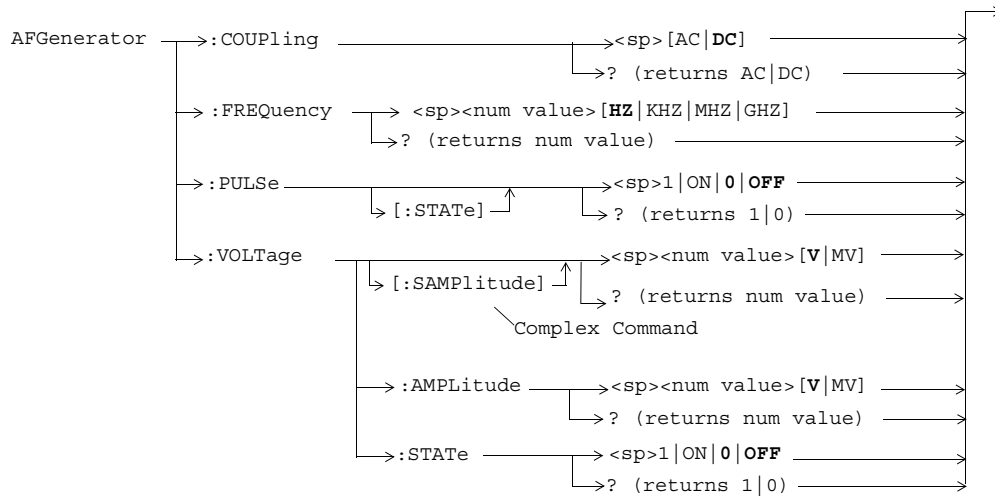
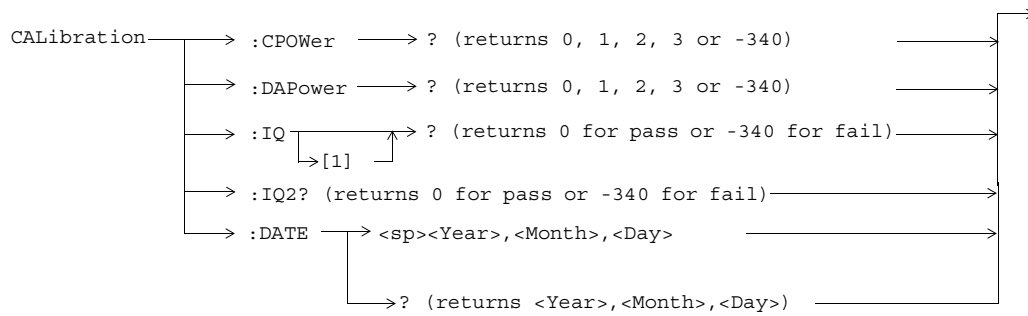
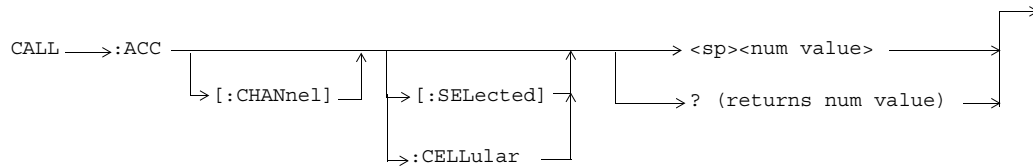

Diagram Conventions

CALibration



CALL:ACC



CALL[:CELL]:APARAmeter

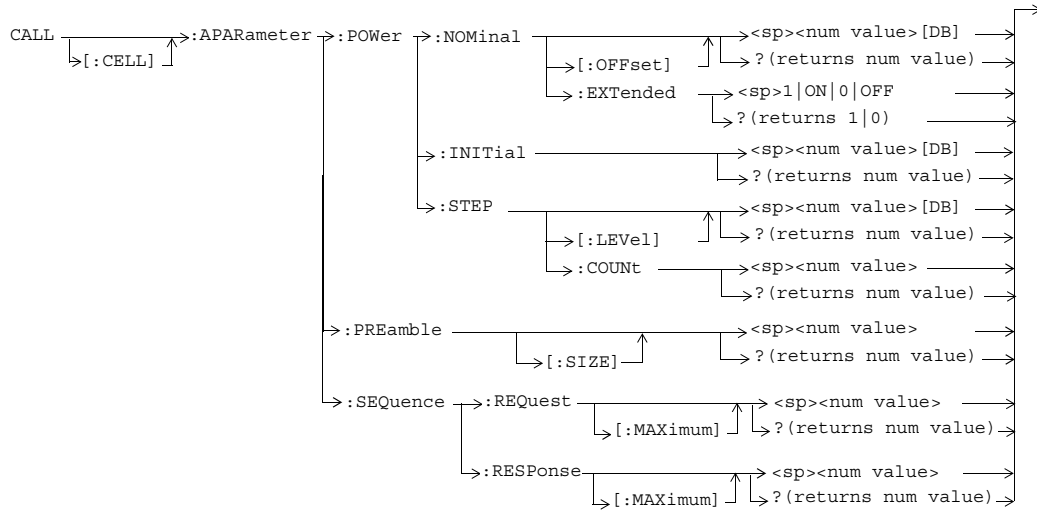

CALL:AVCTest

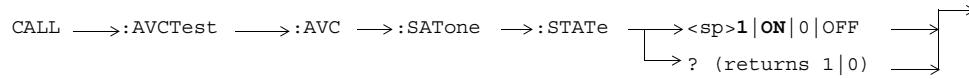
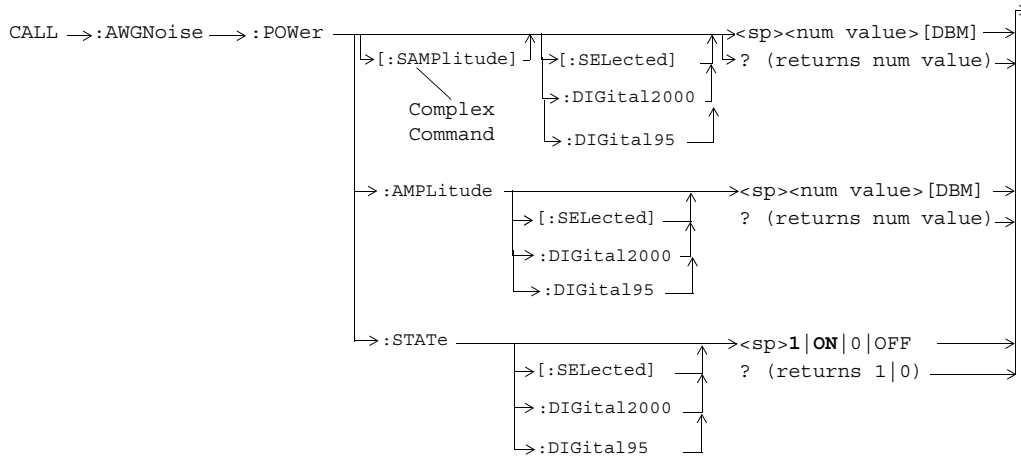
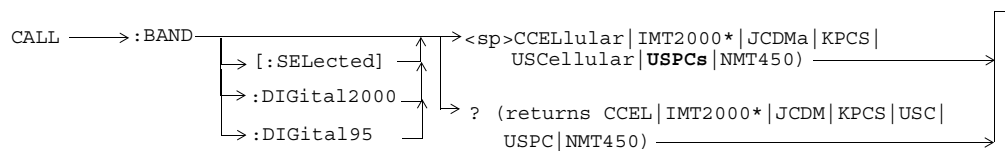

Diagram Conventions

CALL:AWGNoise:POWer



CALL:BAND



* Does not apply to DIGital95

CALL:CHANnel

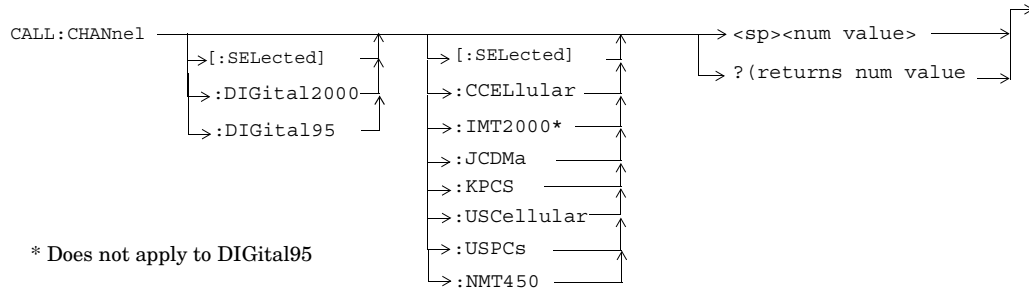

CALL[:CELL]:CLPControl

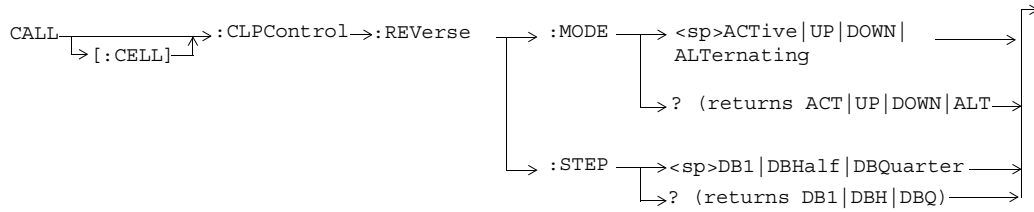
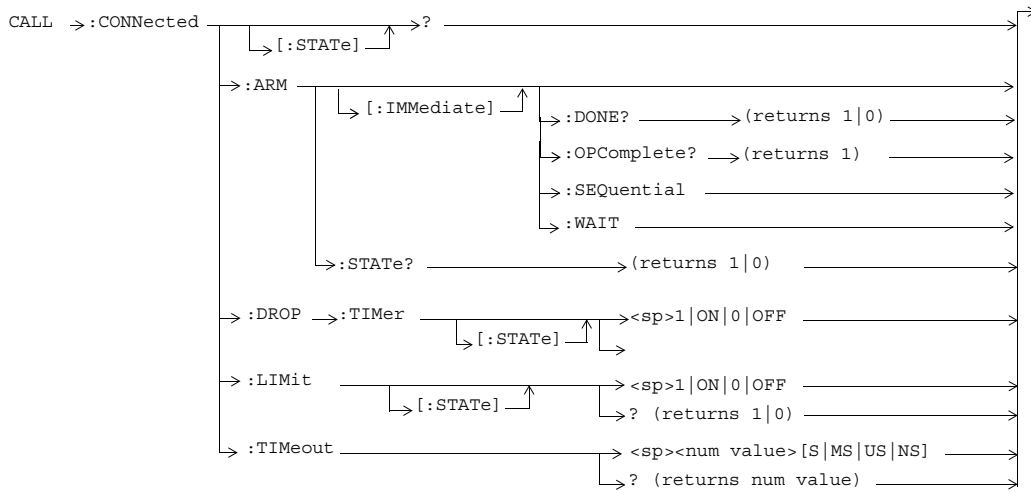
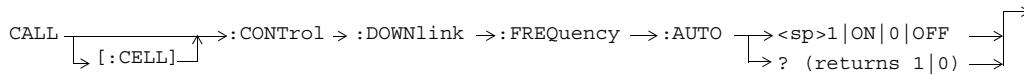

Diagram Conventions

CALL:CONNEcted[:STATe]



CALL[:CELL]:CONTRol:DOWNlink:FREQuency:AUTO



CALL:D2KTest

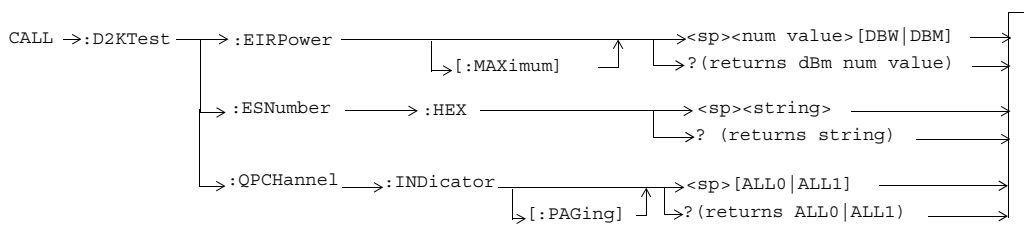

CALL:DCONnected[:STATe]

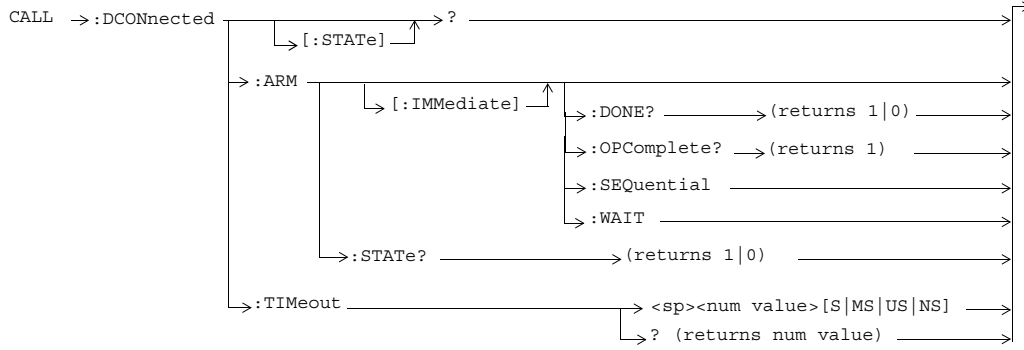

CALL:END

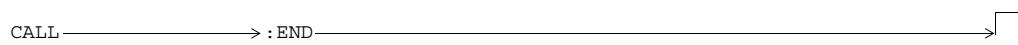

CALL[:CELL]:ESCape[:MODE]

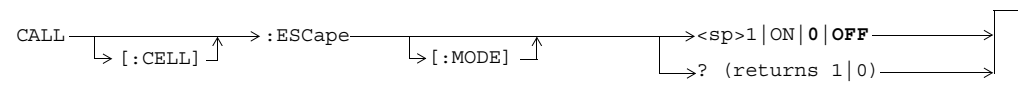
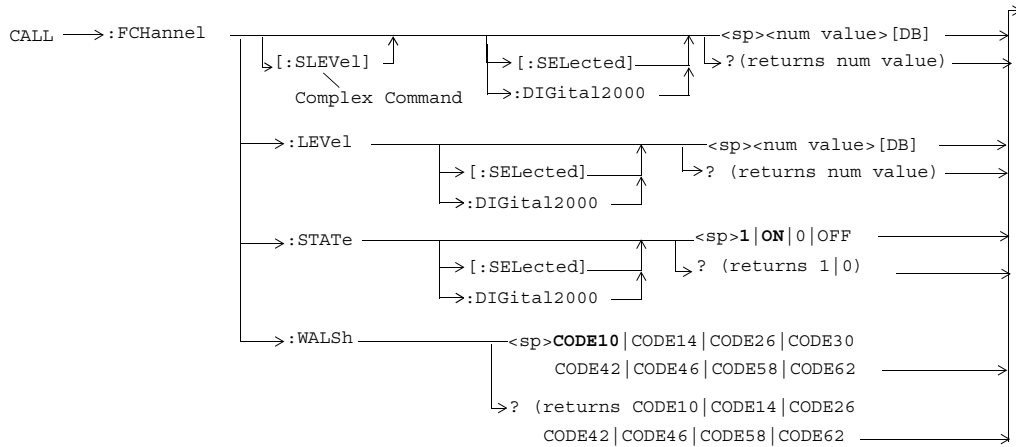
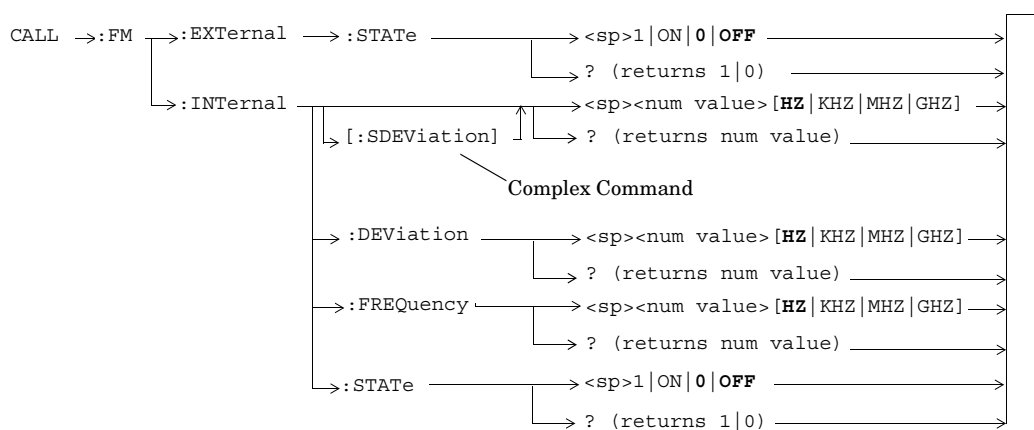

Diagram Conventions

CALL:FCHannel



CALL:FM



CALL:HANDoff

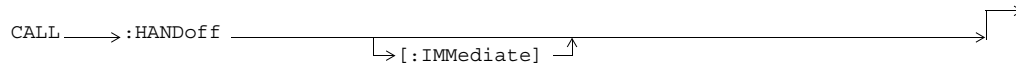

CALL[:CELL]:MCCCode

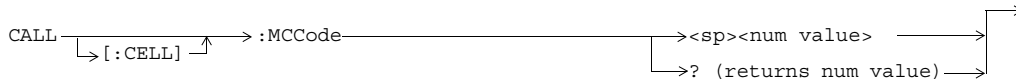

CALL[:CELL]:MNCCode



CALL:MS:ANALog

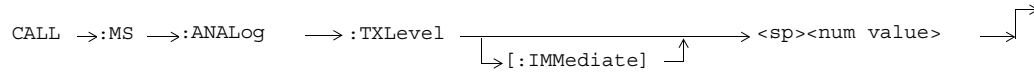

CALL:MS:REPorted:<BCL,BWT>

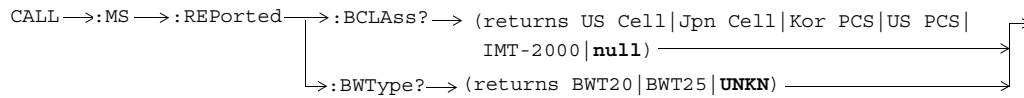
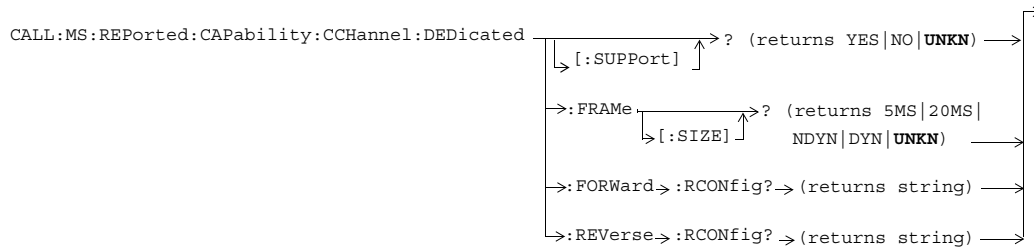
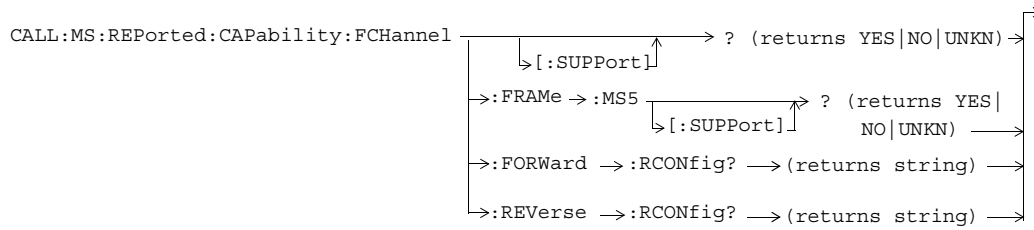

Diagram Conventions

CALL:MS:REPorted:CAPability:CCHannel:DEDicated



CALL:MS:REPorted:CAPability:FCHannel



CALL:MS:REPorted:CAPability:QUERy

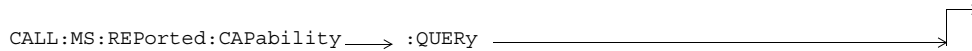

CALL:MS:REPorted:CAPability:SCHannel:FORward

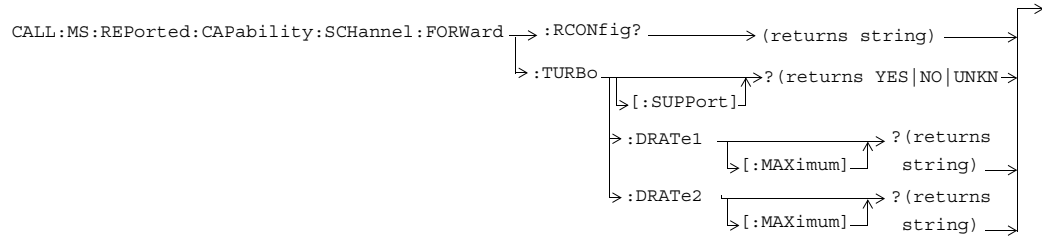
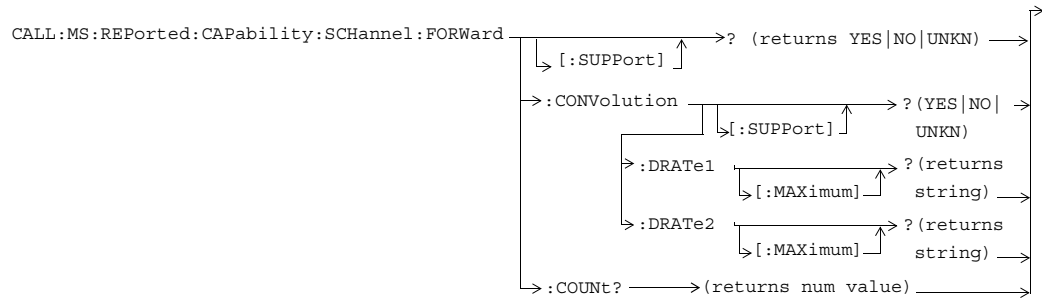
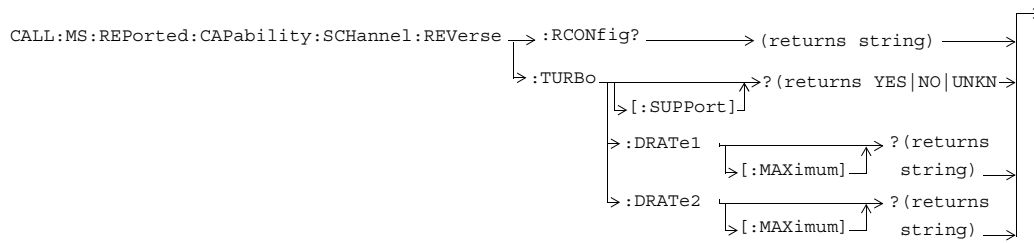
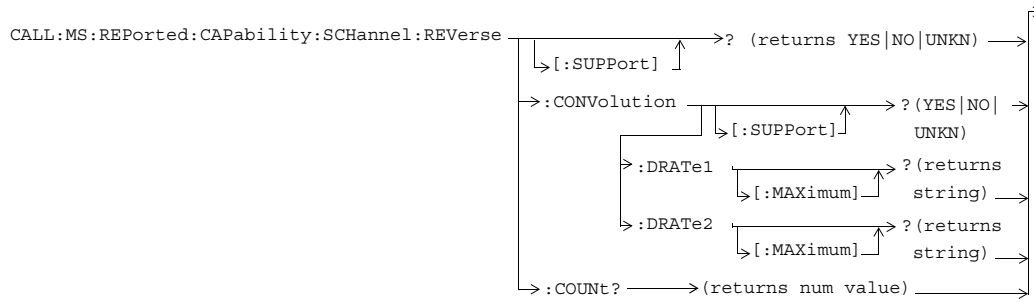
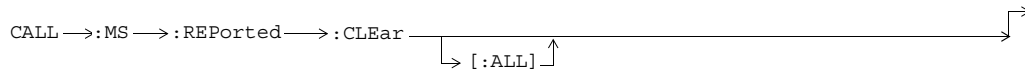

Diagram Conventions

CALL:MS:REPorted:CAPability:SCHannel:REVerse



CALL:MS:REPorted:CLEar



CALL:MS:REPorted:CPClass

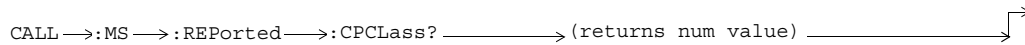

CALL:MS:REPorted:CTXType

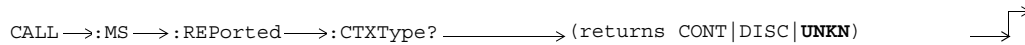

CALL:MS:REPorted:DUAL[:MODE]

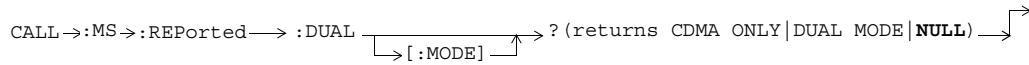

CALL:MS:REPorted:<EIRP,ESN>

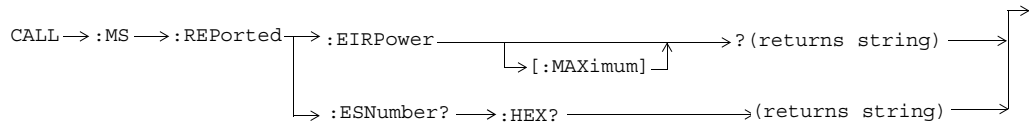

CALL:MS:REPorted:<MCC,MIN1,MIN2,MNC,MSIN>

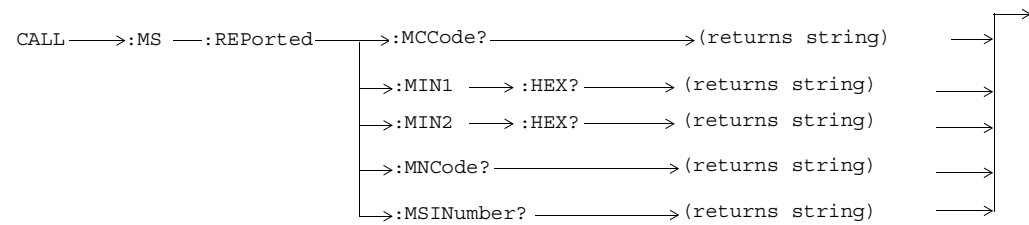

CALL:MS:REPorted:<ONUM,OPER,PCL,PCON,PNUM,PREV,QPCH>

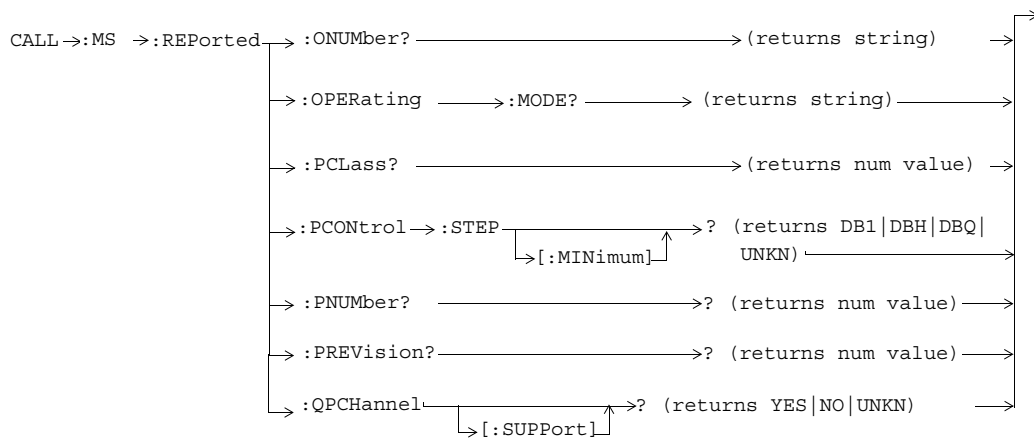
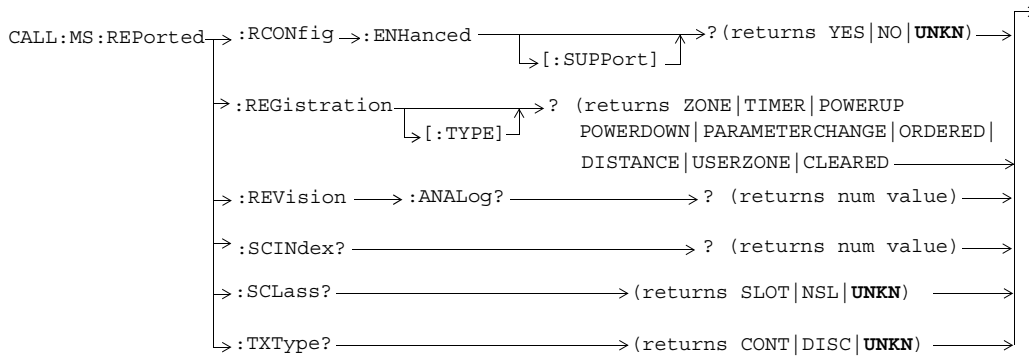
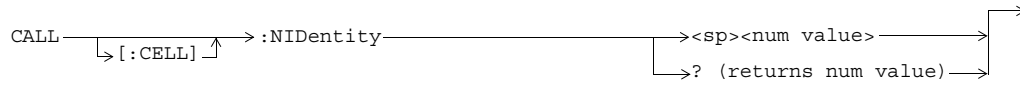

Diagram Conventions

CALL:MS:REPorted:<RCON,REG,REV,SCIN,SCL,TXT>



CALL[:CELL]:NIDentity



CALL:OCNSource

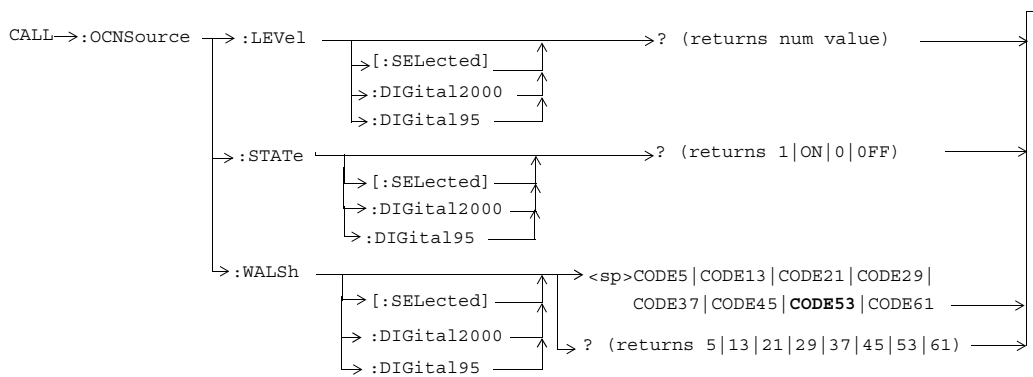

CALL[:CELL]:OPERating

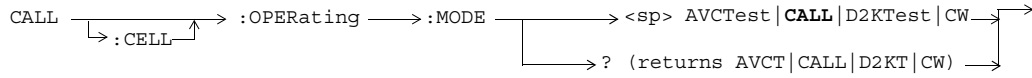

CALL:ORIGinate

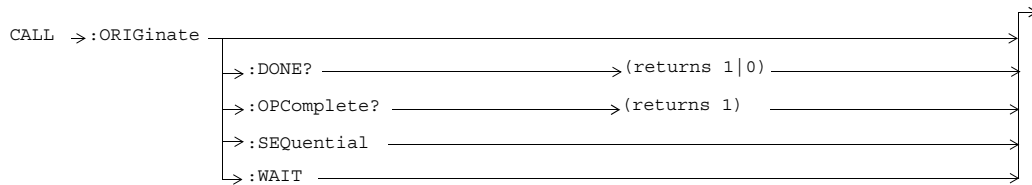

CALL:ORIGinate

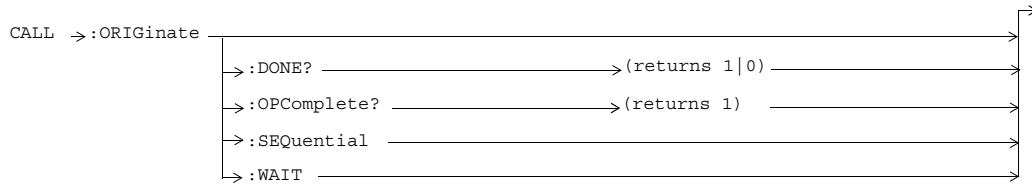
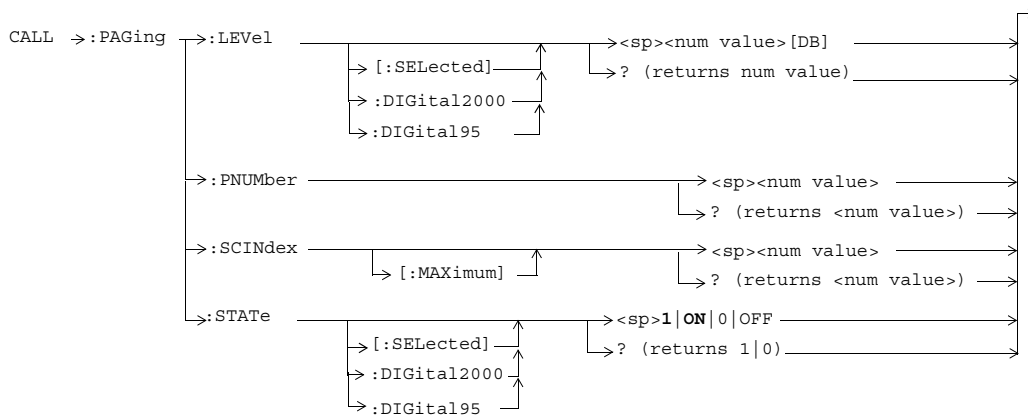
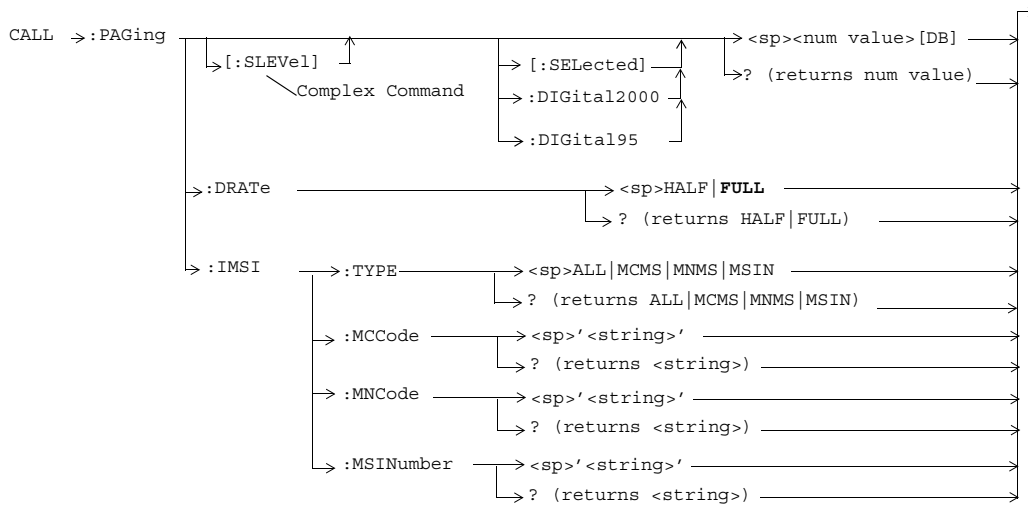
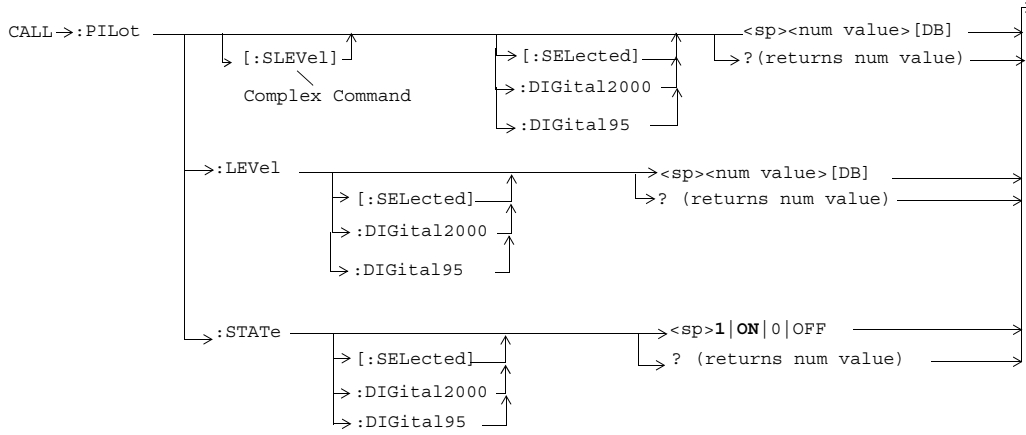

Diagram Conventions

CALL:PAGing



CALL:PILot



CALL[:CELL]:PNOffset

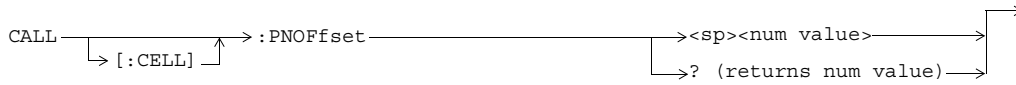
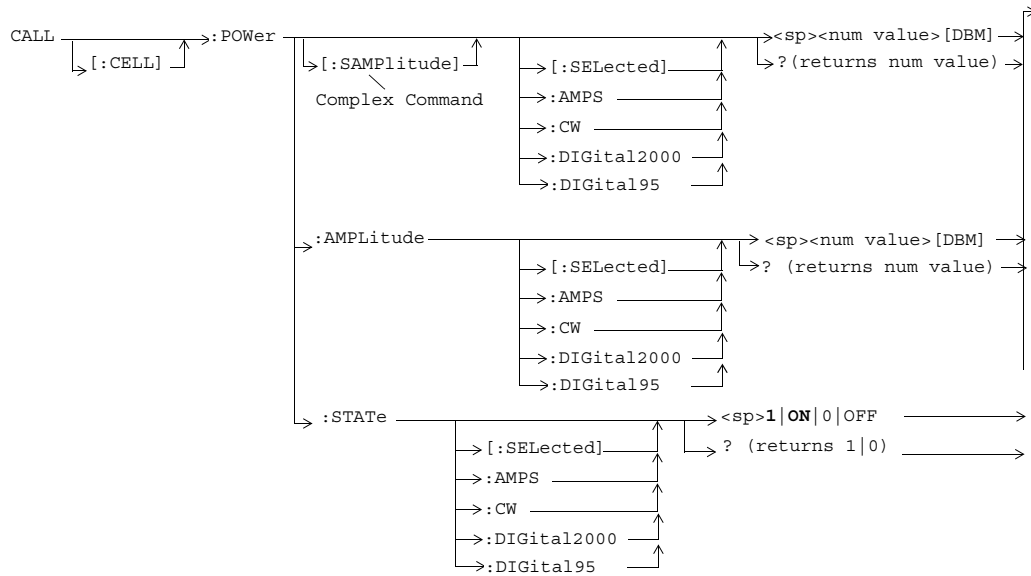

Diagram Conventions

CALL[:CELL]:POWer



CALL[:CELL]:PROTOcol

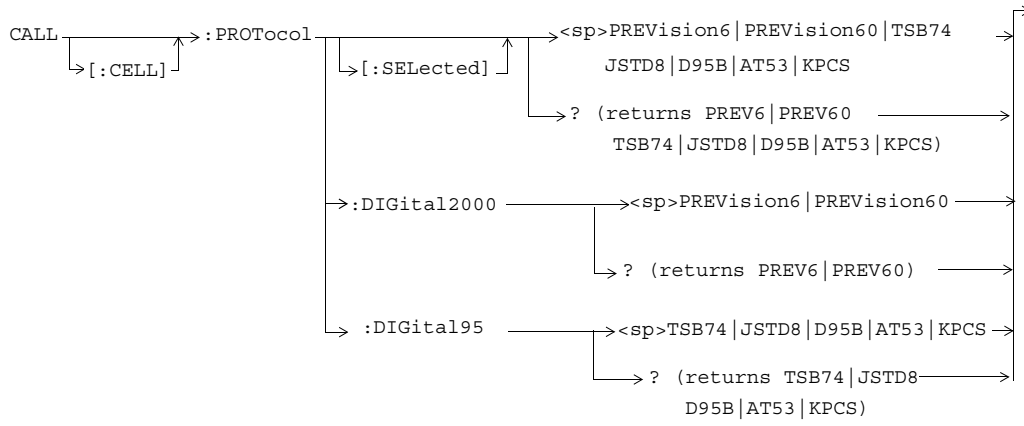
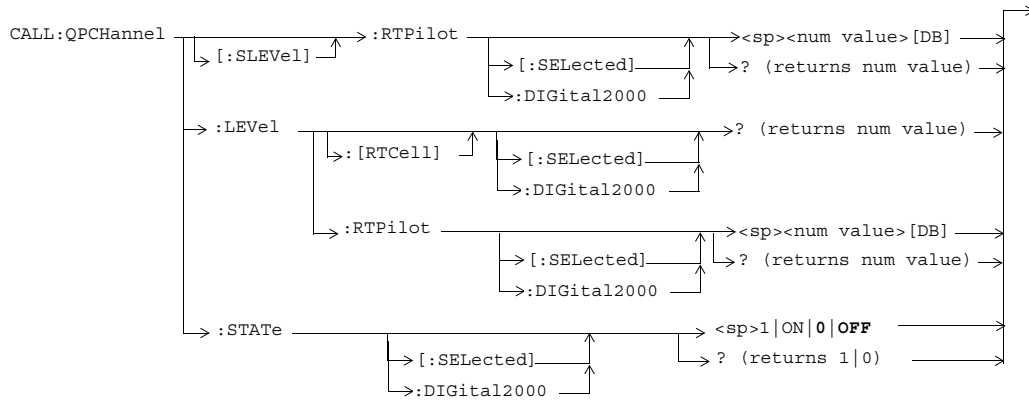
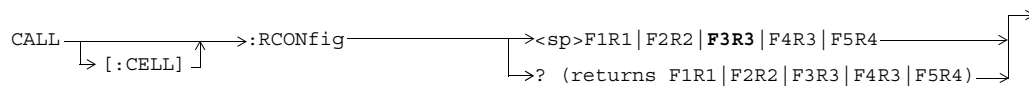

Diagram Conventions

CALL:QPCHannel



CALL[:CELL]:RCONfig



CALL:REGister

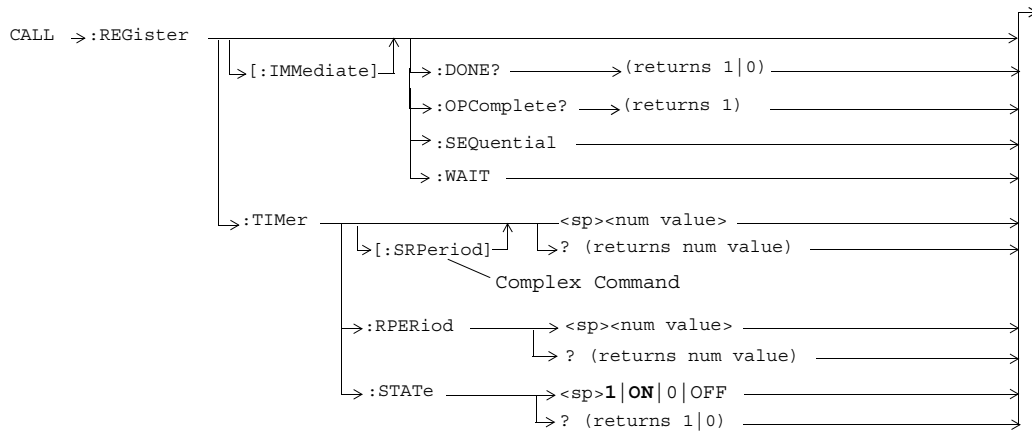

CALL[:CELL]:RFGenerator

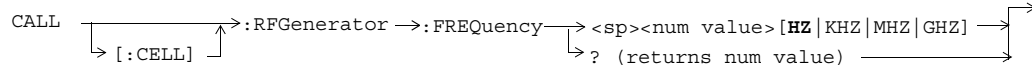

CALL[:CELL]:RLGain

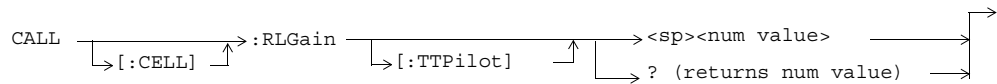
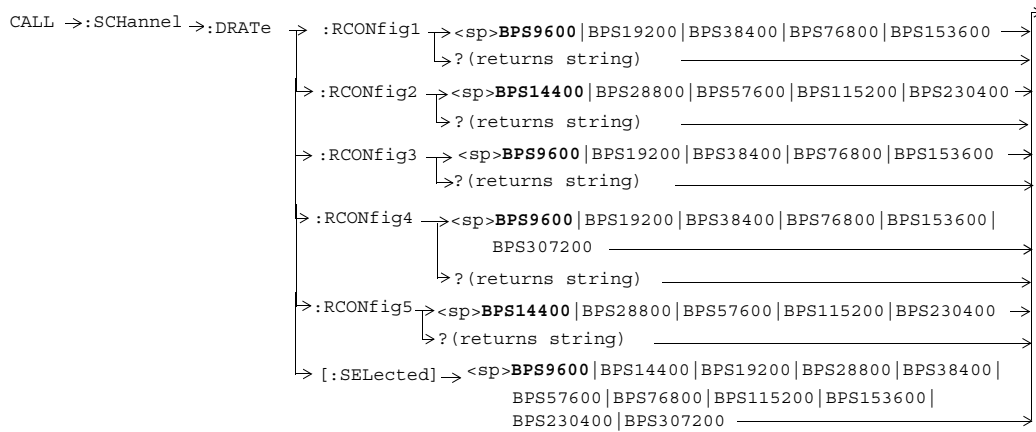
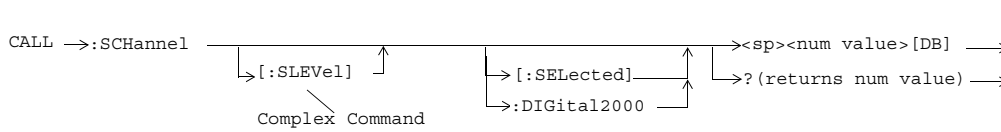
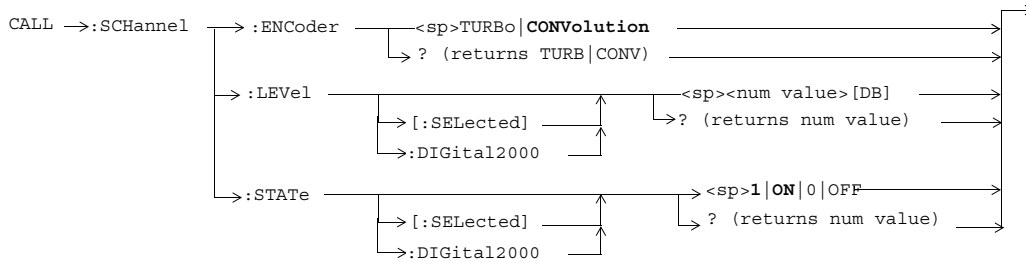

Diagram Conventions

CALL:SCHannel



Note: Data rates used with the SELEcted keyword must be compatible with the currently selected radio configuration. If a data rate that does not belong to the selected radio configuration's rate set is used, an error message will be generated.



CALL:SETup:AVC

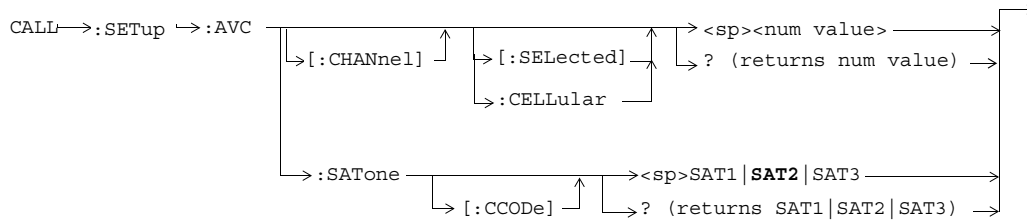

CALL:SETup:BAND

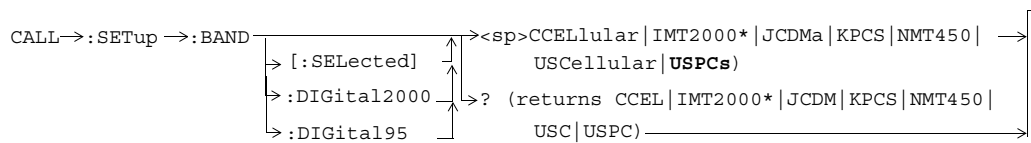

* Does not apply to DIGital95

CALL:SETup:CHANnel

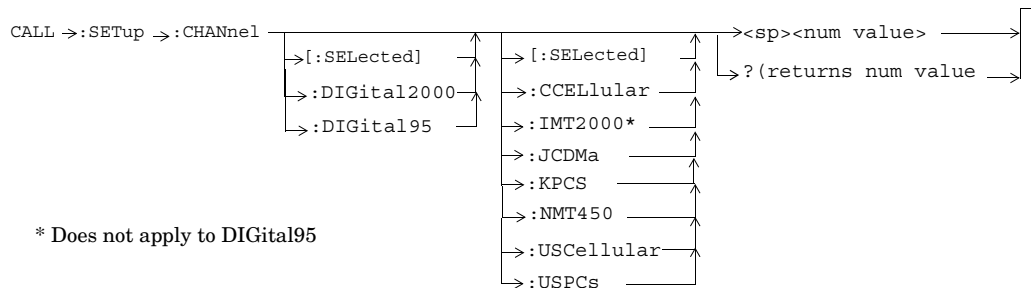

* Does not apply to DIGital95

CALL:SETup:HANDoff

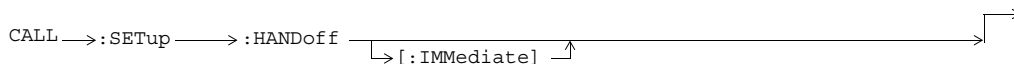
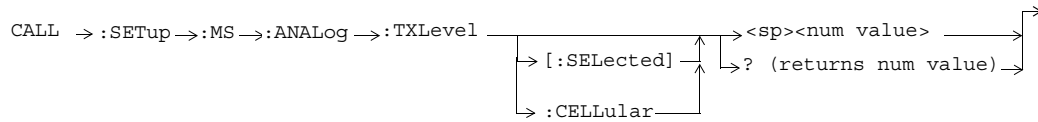
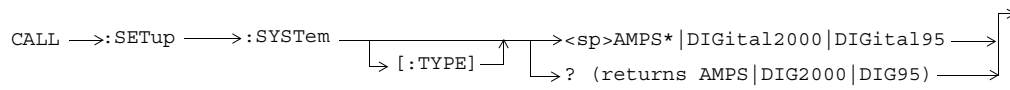

Diagram Conventions

CALL:SETup:MS:ANALog



CALL:SETup:SYSTEM



* If the active system type is AMPS, handoffs to other system types are not allowed.

CALL[:CELL]:SIDentity

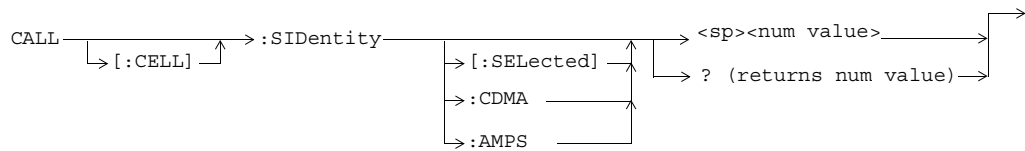

CALL[:CELL]:SOPTION

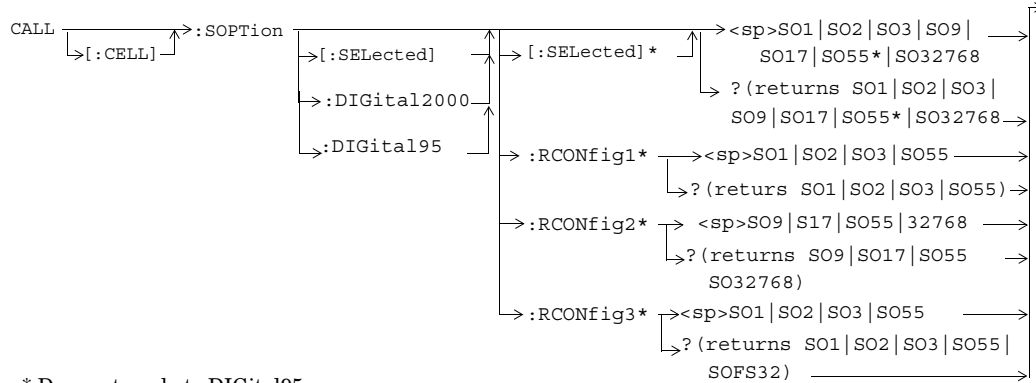

* Does not apply to DIGital95

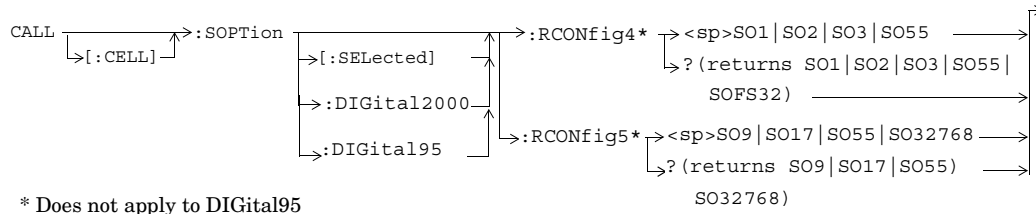

* Does not apply to DIGital95

Diagram Conventions

CALL:STATus

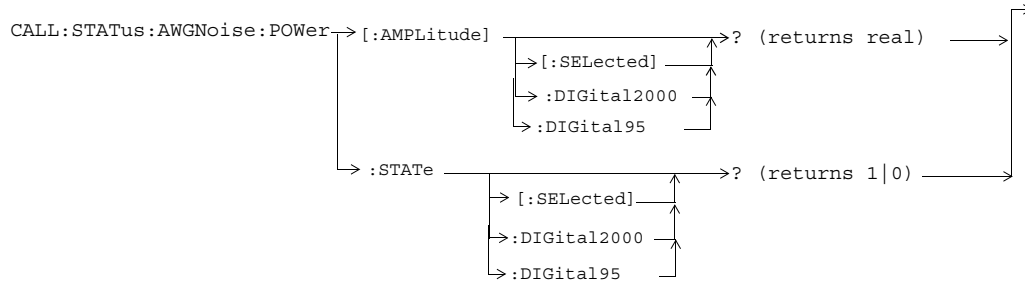
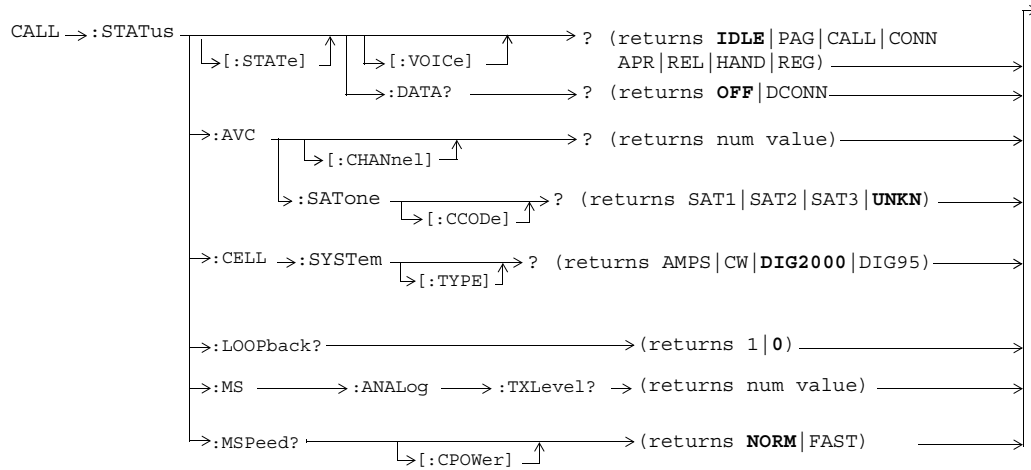

Diagram Conventions

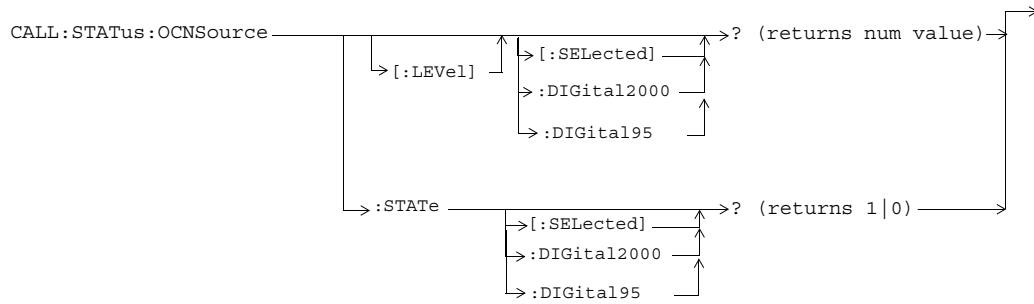
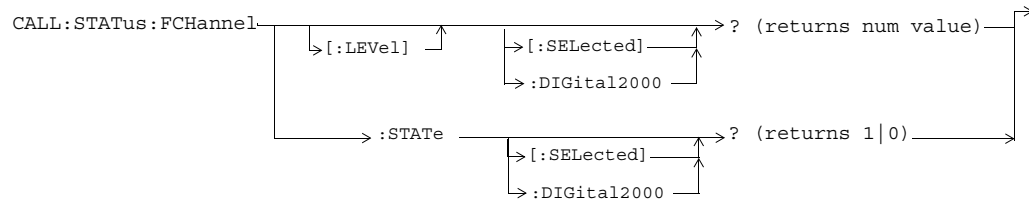
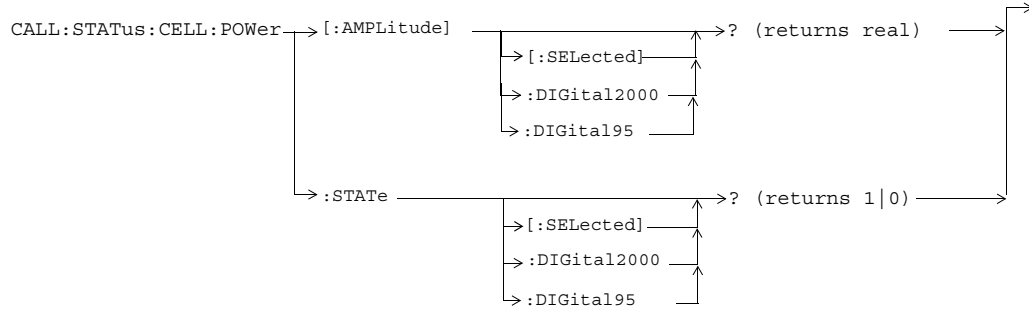

Diagram Conventions

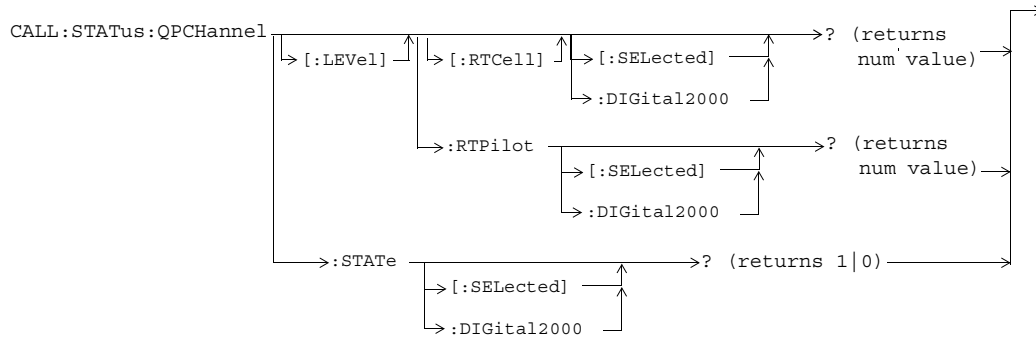
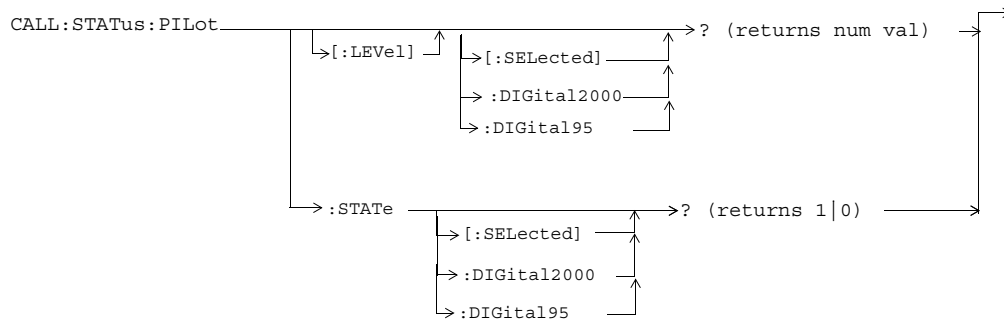
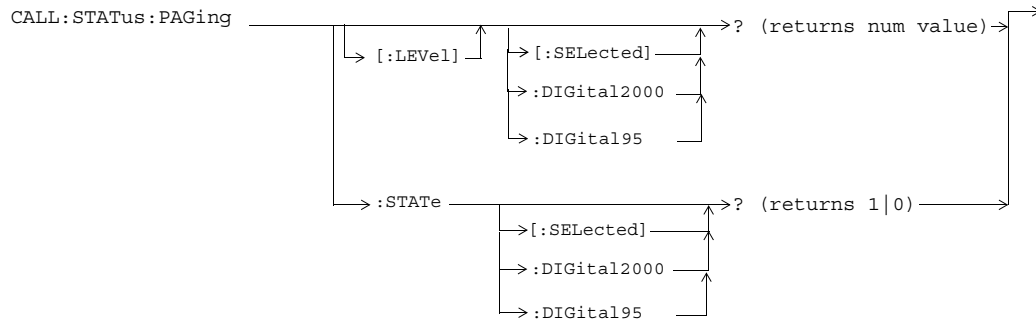

Diagram Conventions

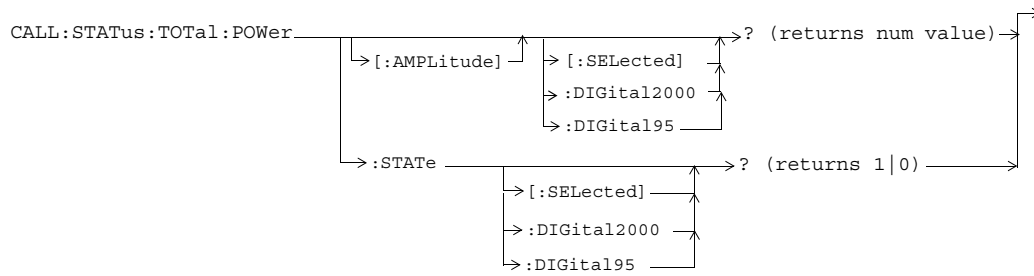
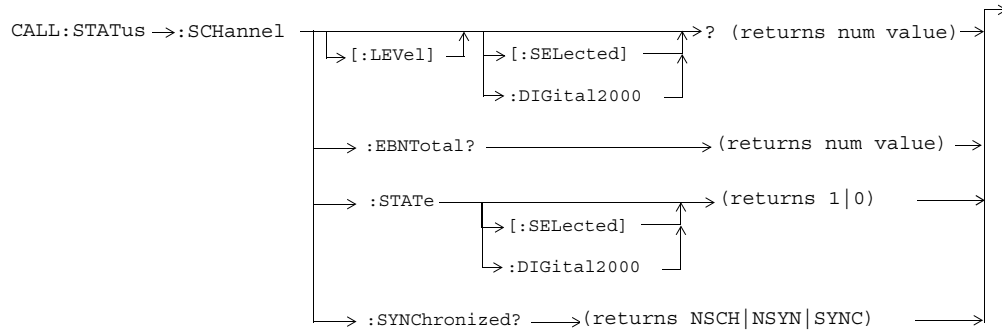
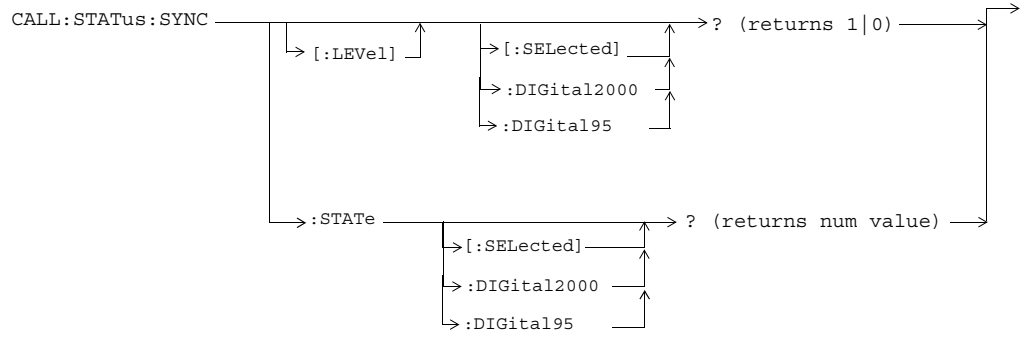
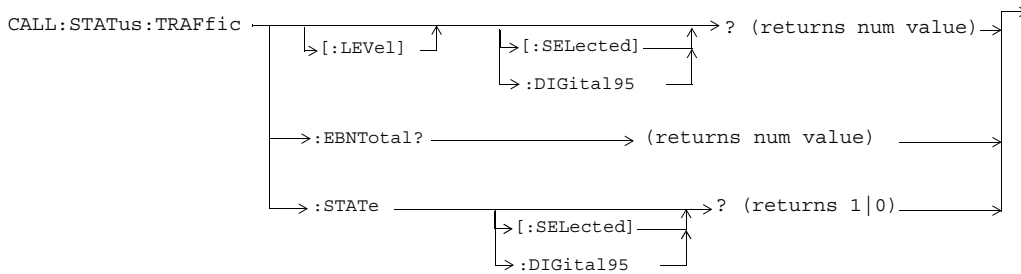
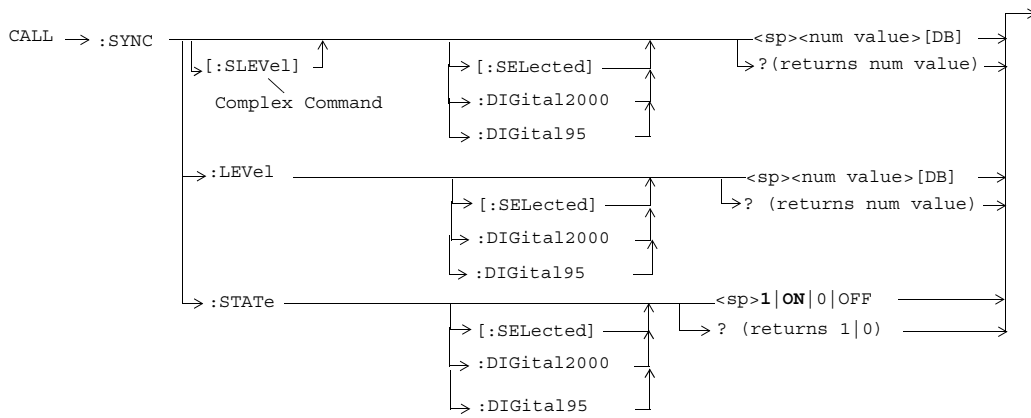

Diagram Conventions



CALL:SYNC



CALL[:CELL]:SYSTEM

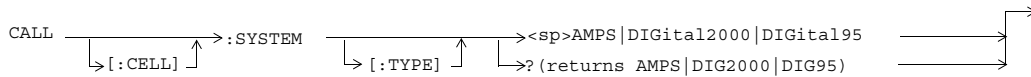

CALL:TOTAl:POWer

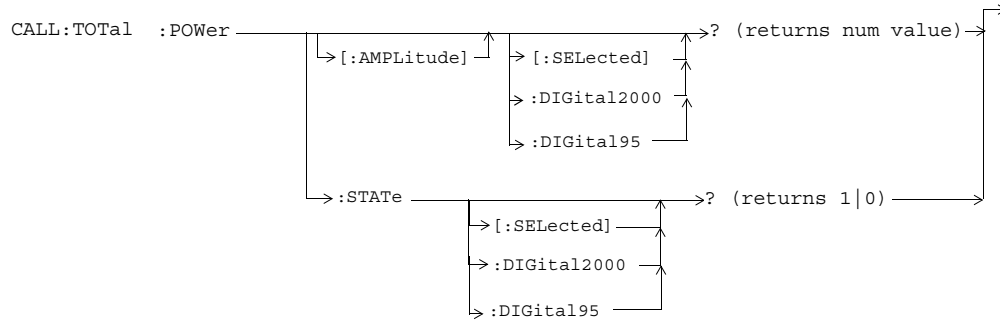

CALL:TRAFfic

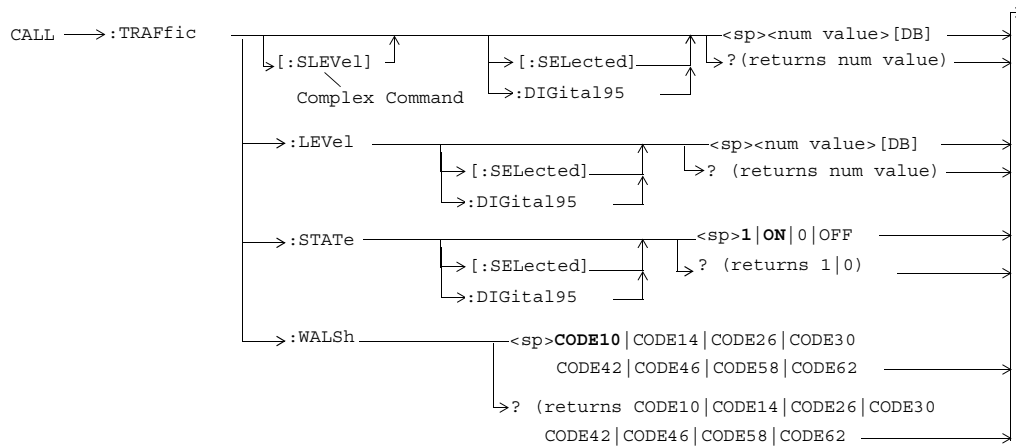
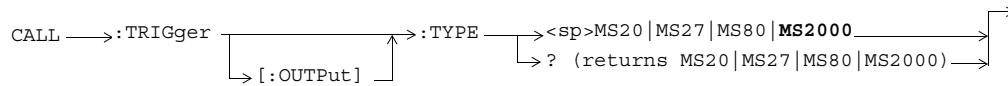
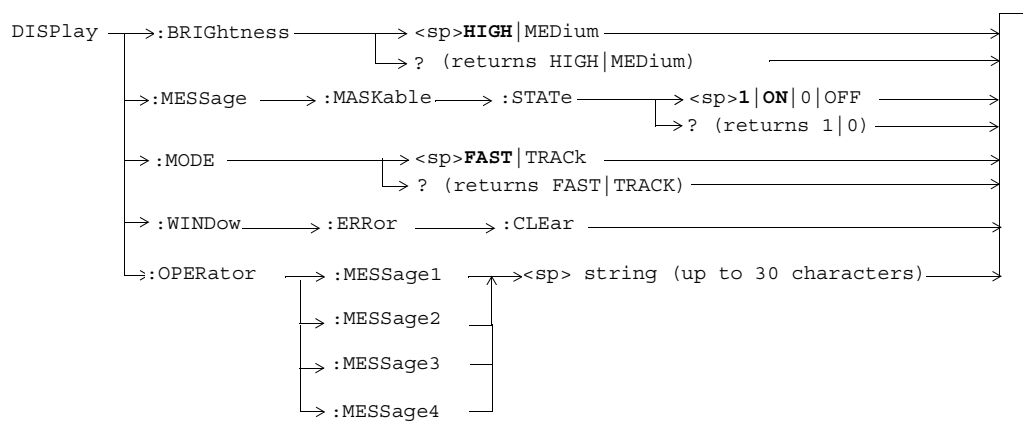

Diagram Conventions

CALL:TRIGger:TYPE



DISPlay



FEtCh:AFANalyzer

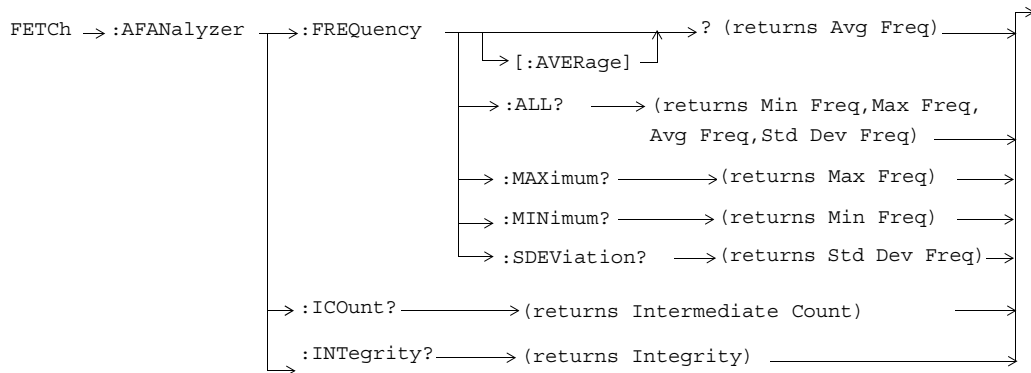
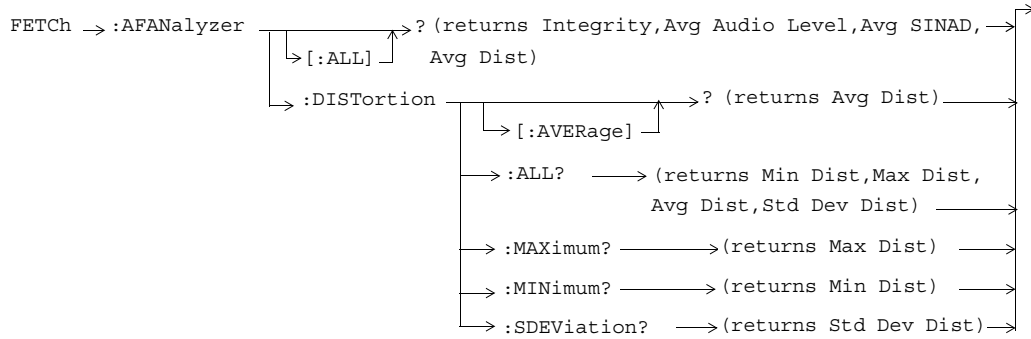
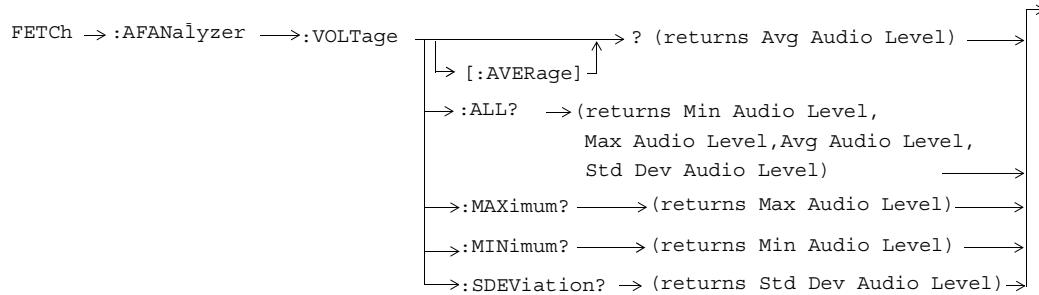
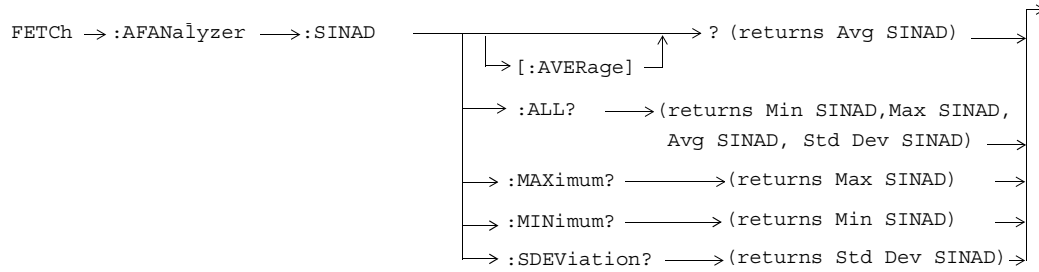
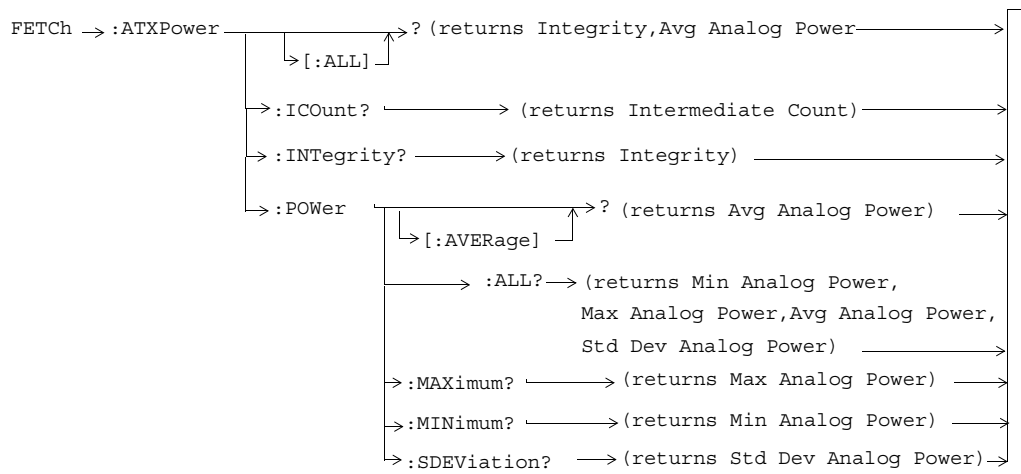

Diagram Conventions



FETCH:ATXPower



FETCH:CAPower

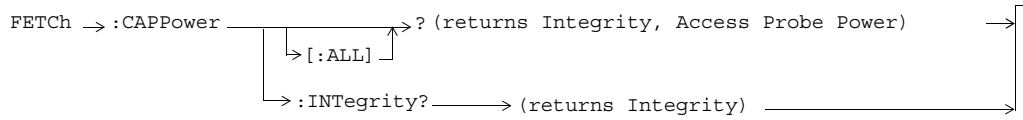
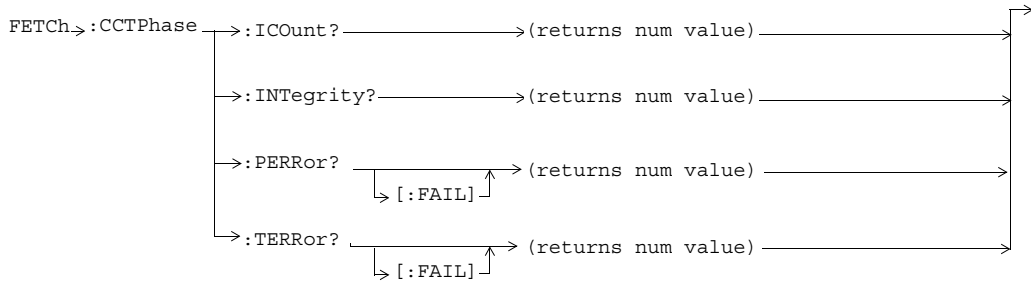
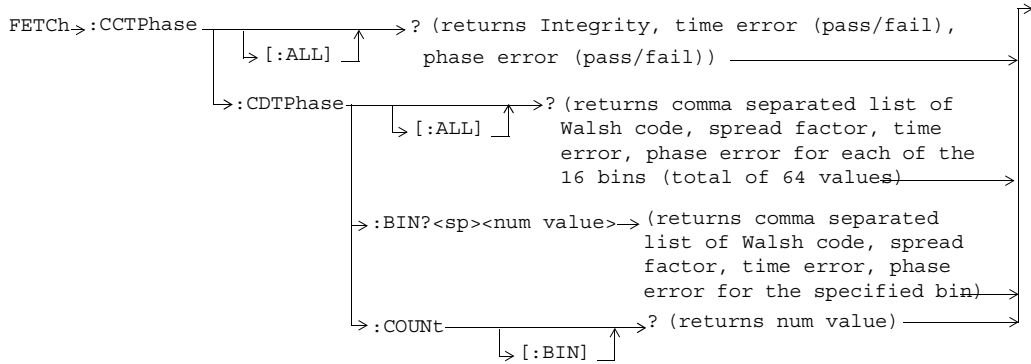
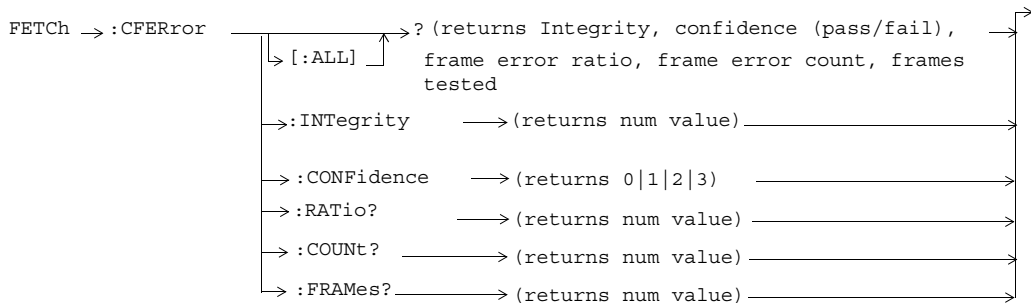

Diagram Conventions

FETCH:CCTPhase



FETCH:CFERror



FETCh:CPOwer

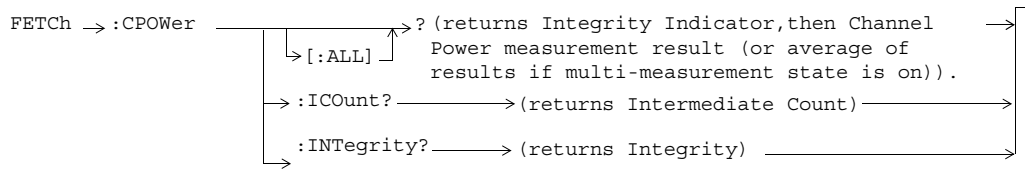

FETCh:CTXSpurious

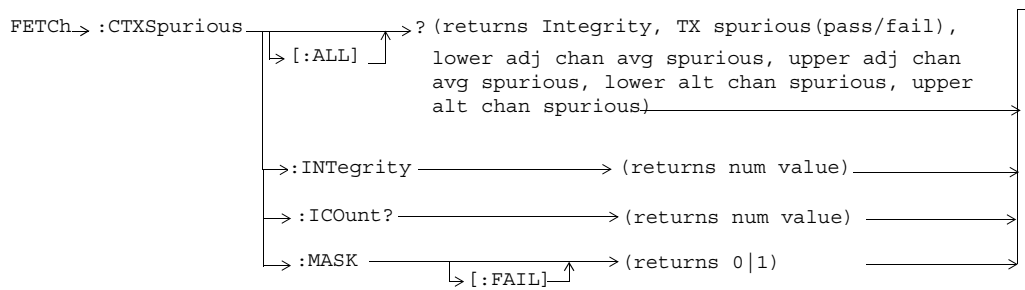

FETCh:DAPower

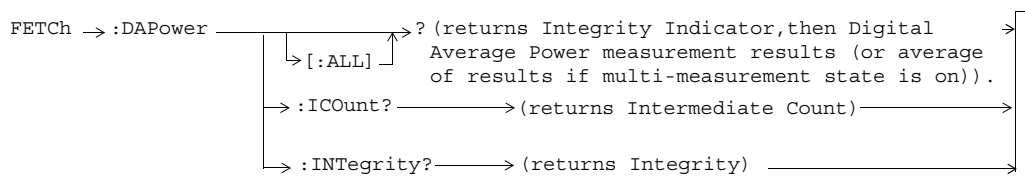
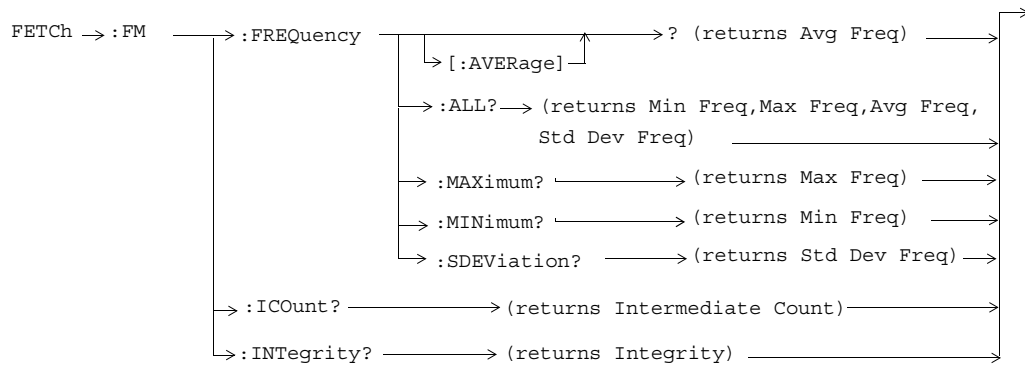
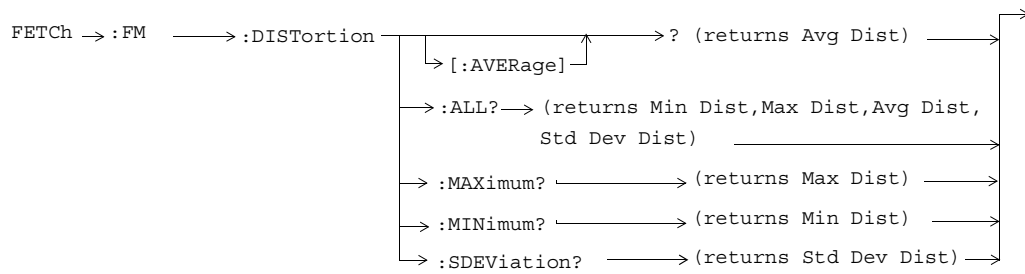
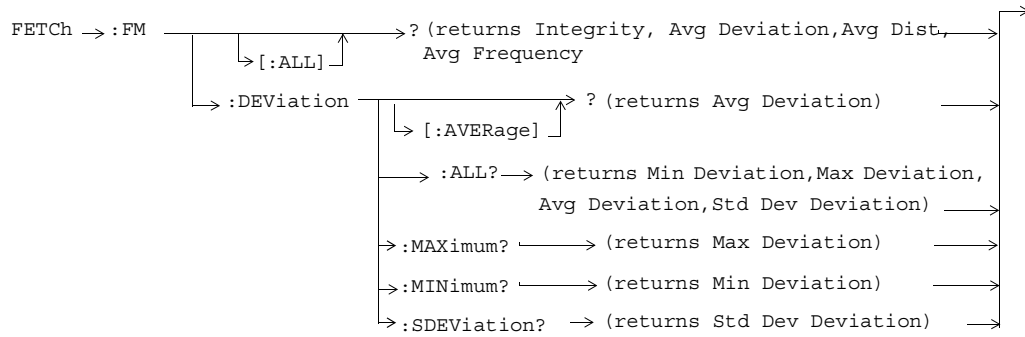

Diagram Conventions

FETCH:FM



FETCH:FSTability

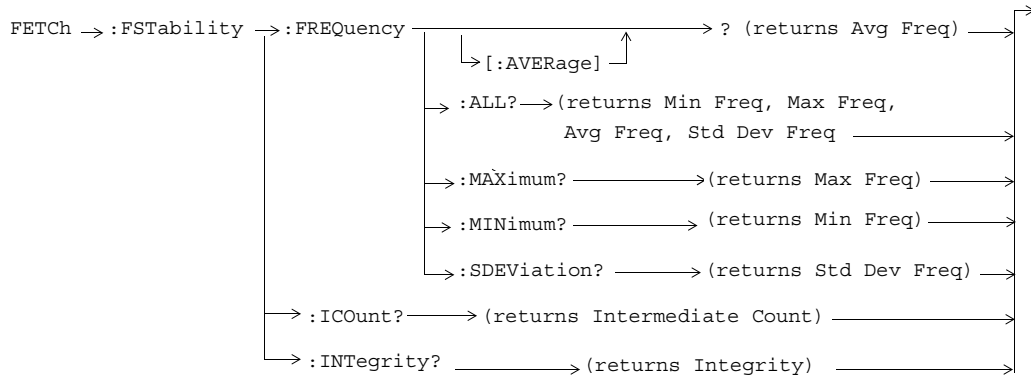
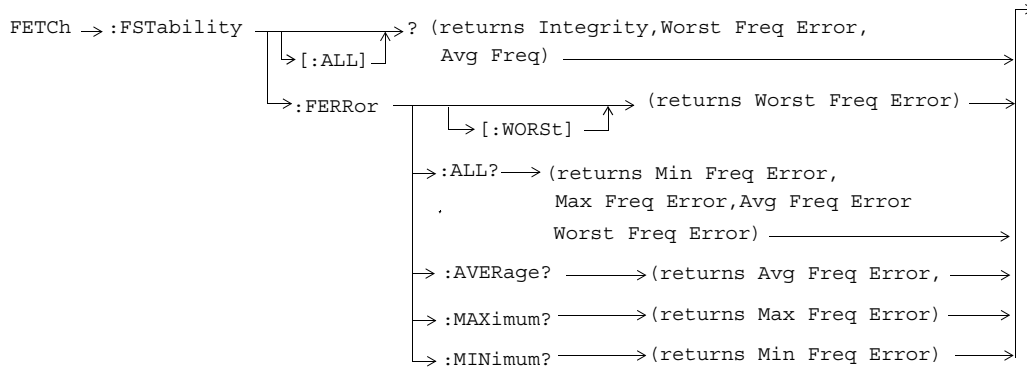
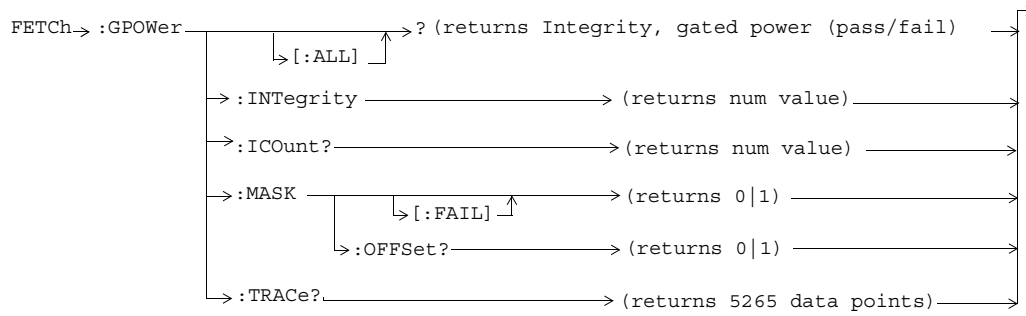
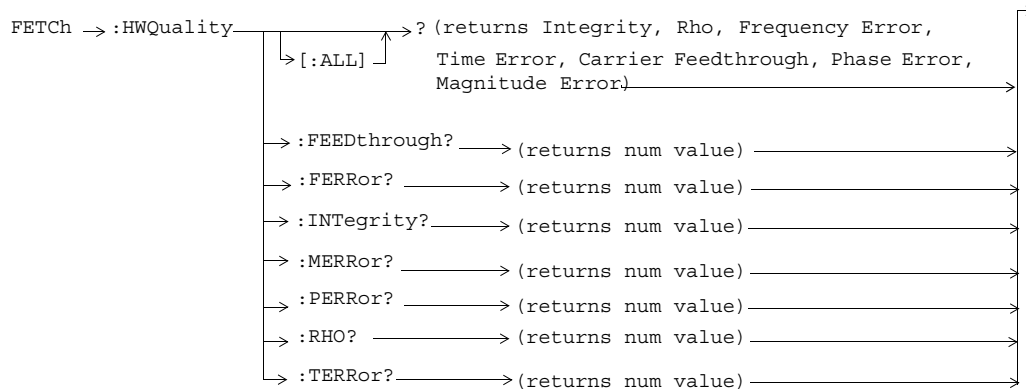

Diagram Conventions

FETCH:GPOWer



FETCH:HWQuality



FETCh:SAUDio

Diagram Conventions

FETCH:TFERror



FETCH:WQuality

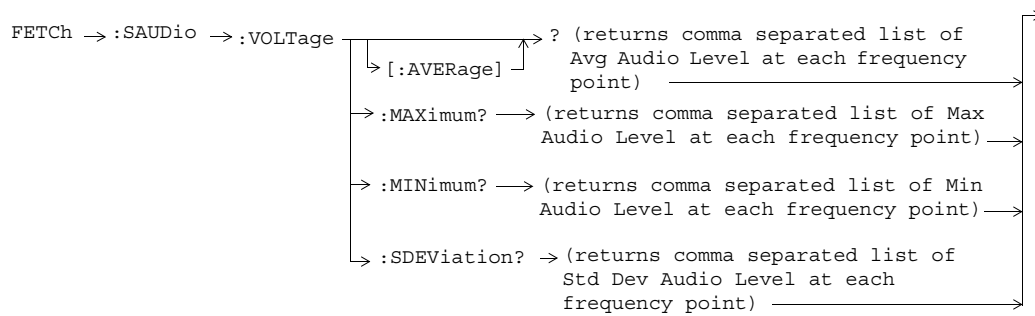
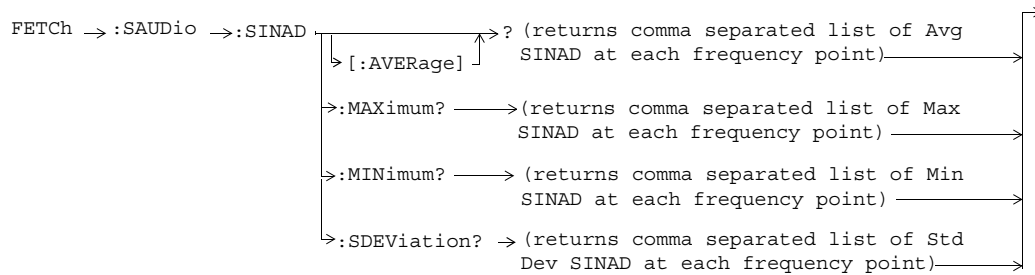
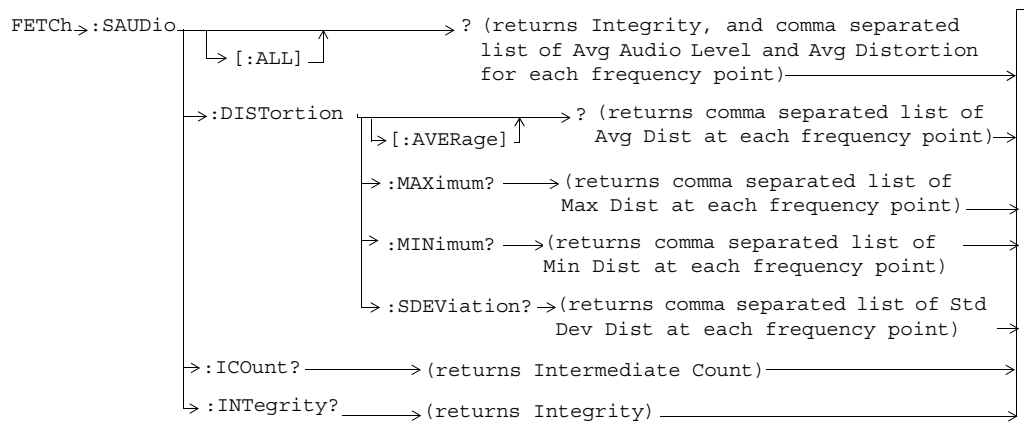
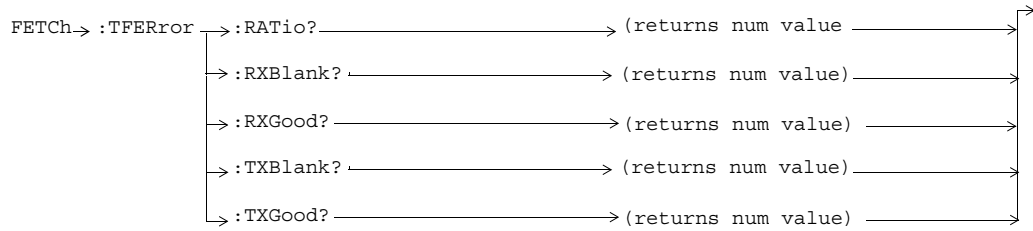
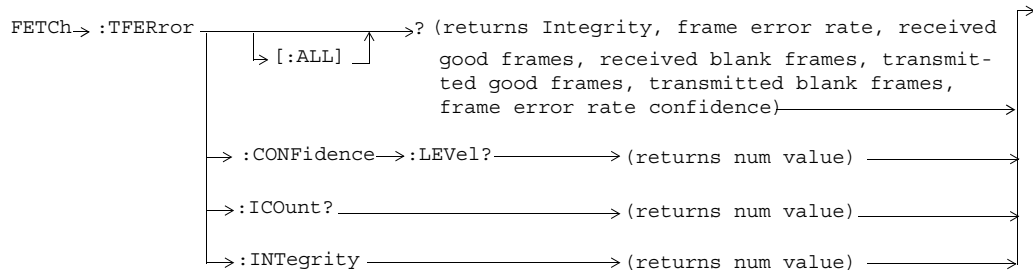
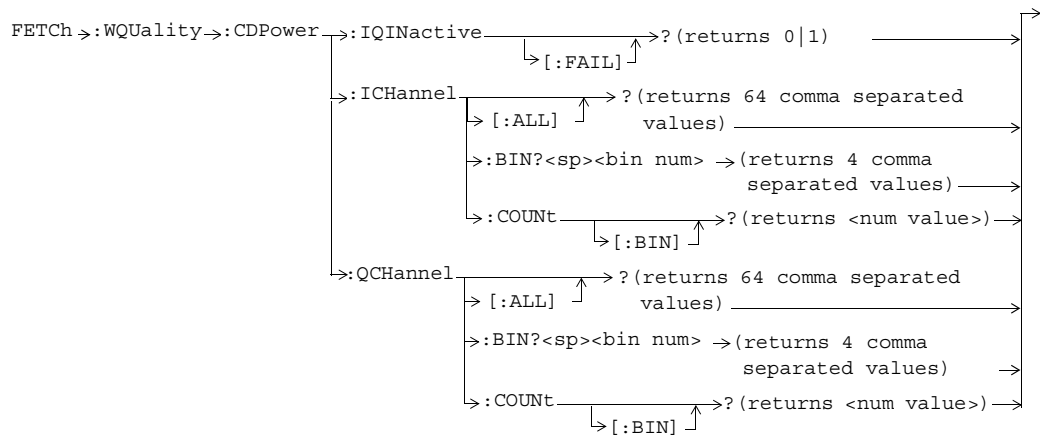
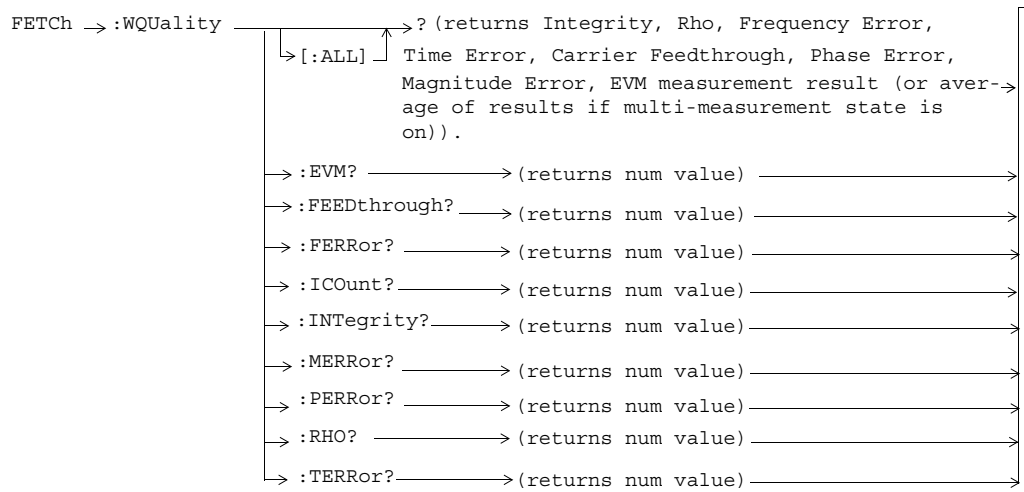
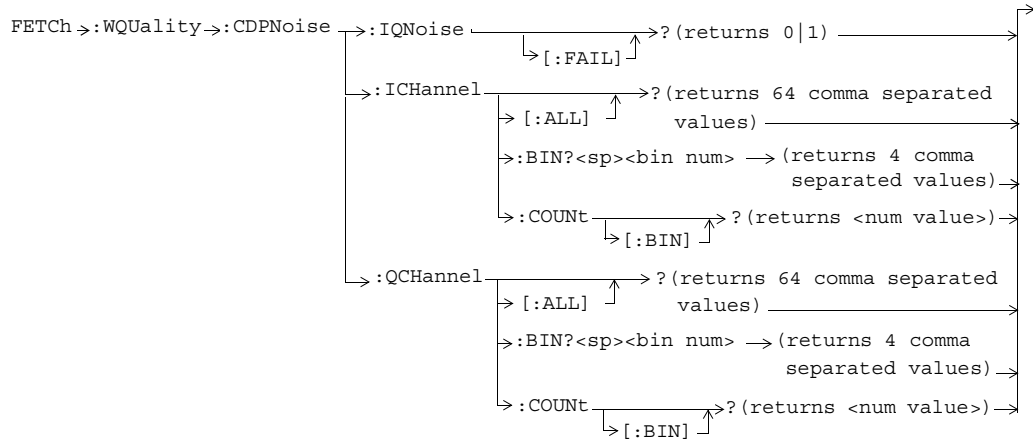

Diagram Conventions



INITiate

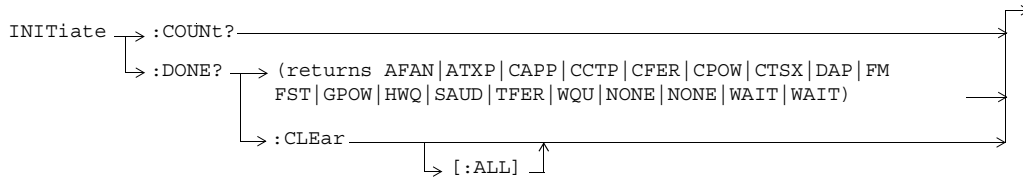
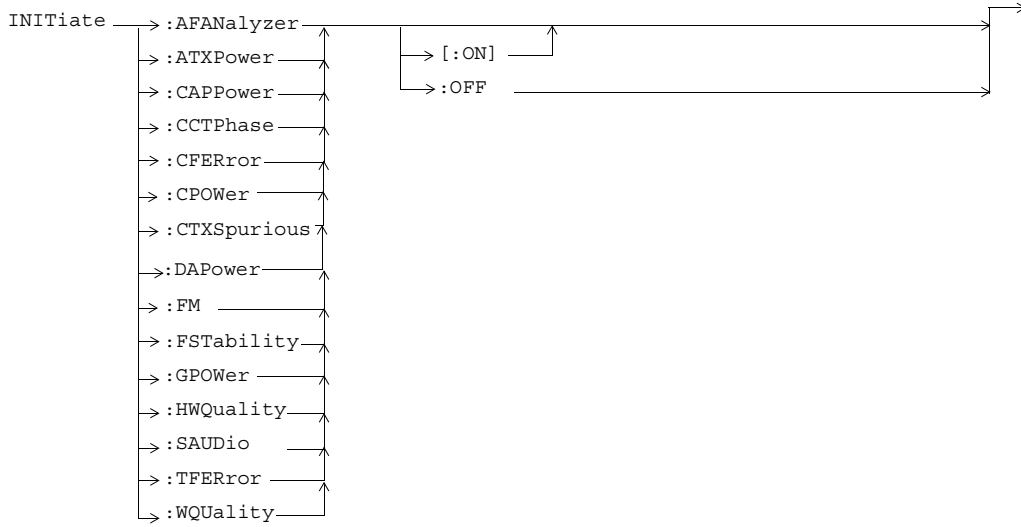
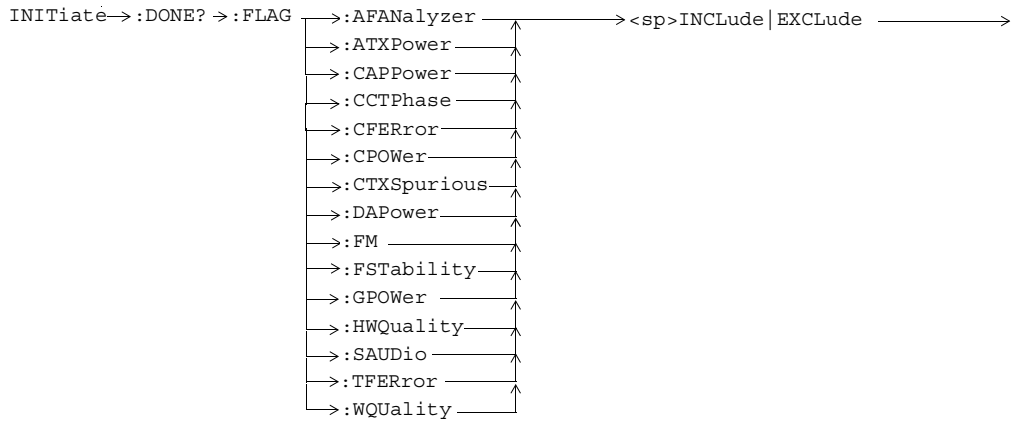

Diagram Conventions



INITiate->:ON? → (returns comma-separated list of AFAN|ATXP|CAPP|CCTP|CFER|CPOW|CTSX|DAP|FM|FST|GPOW|HWQ|SAUD|TFER|WQU|NONE)



READ

Diagram Conventions



RFANalyzer

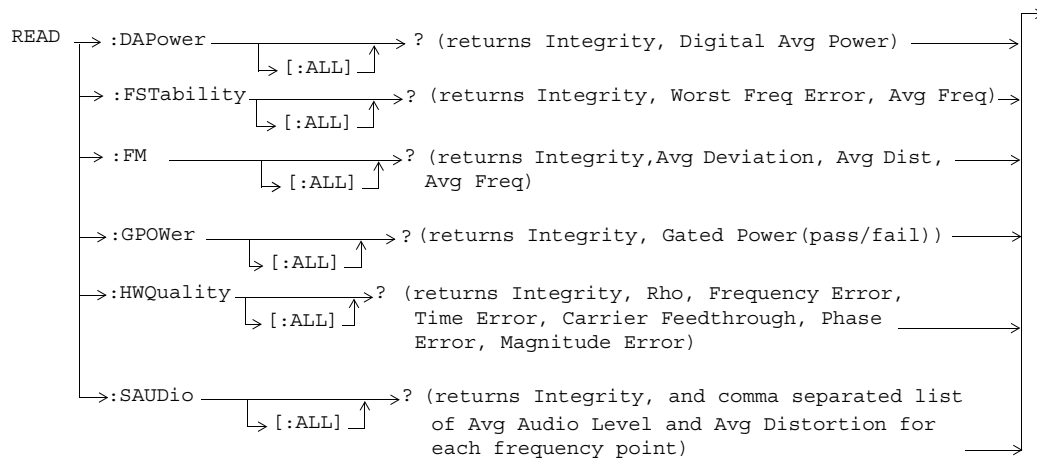
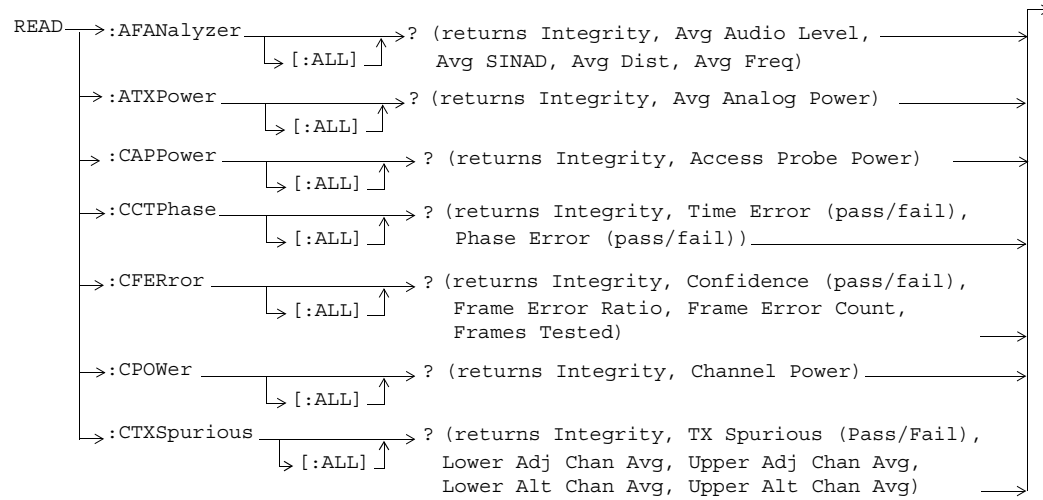
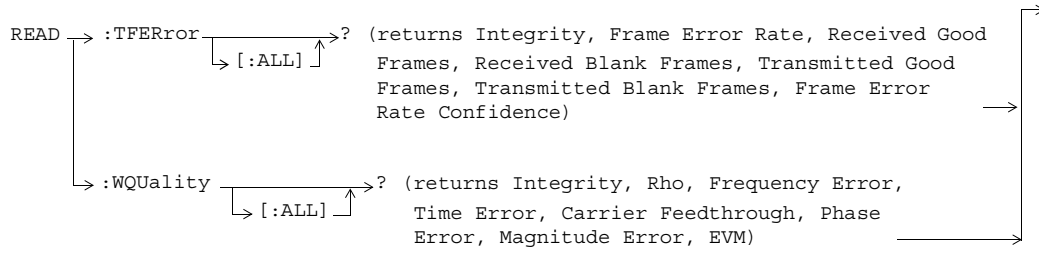
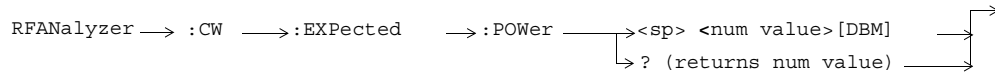
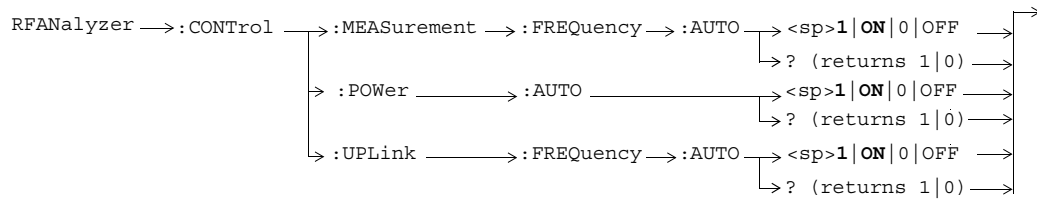
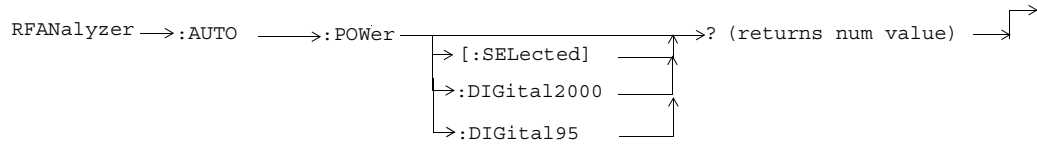
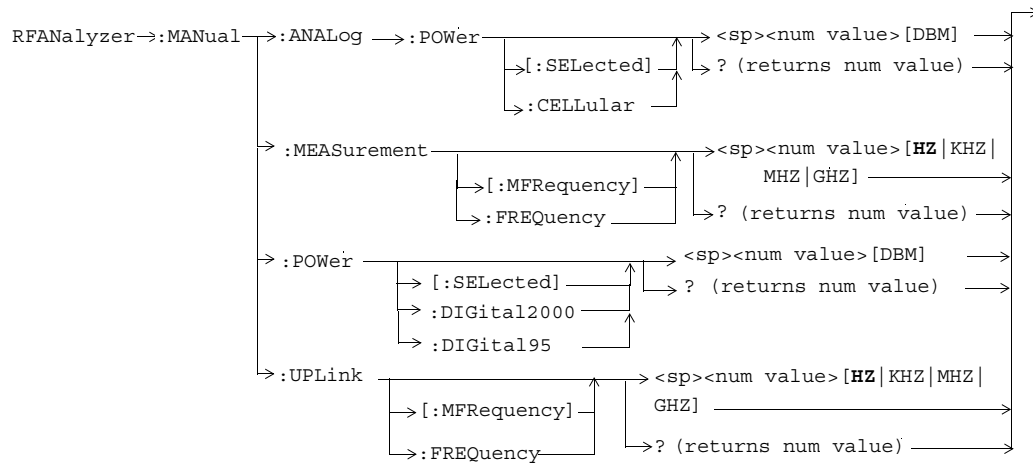

Diagram Conventions



SETup:AFANalyzer

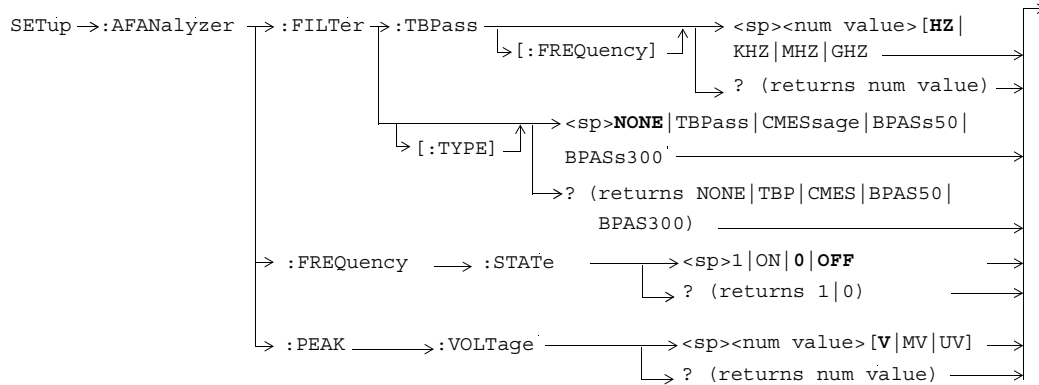
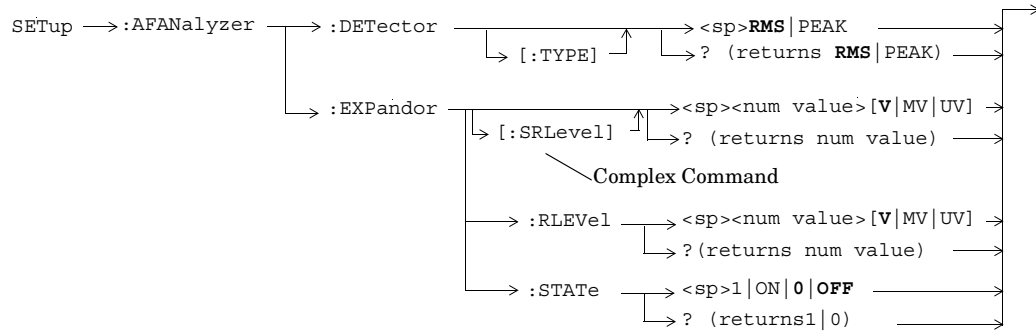
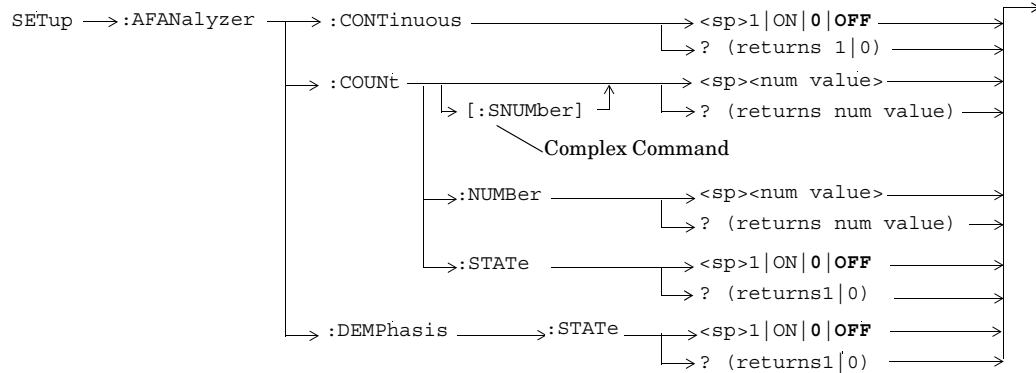
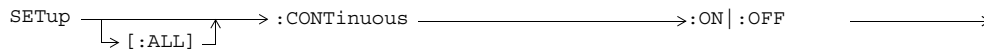
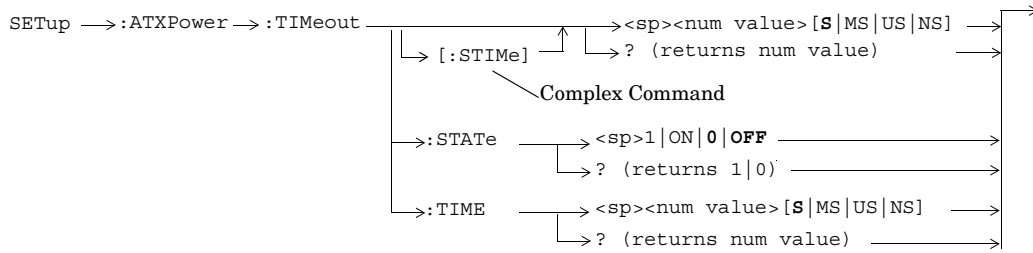
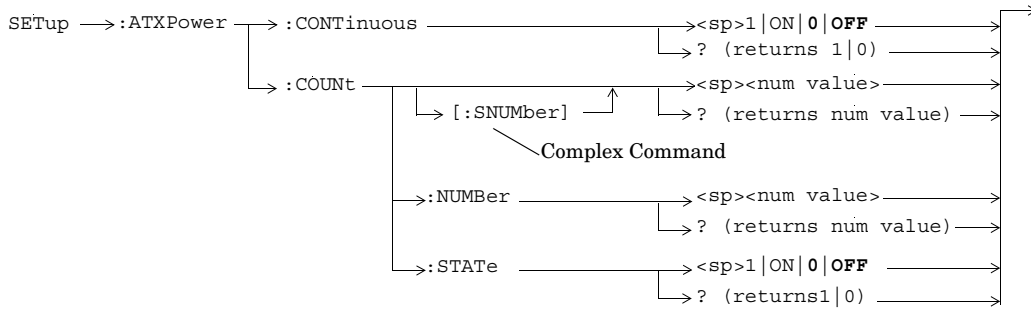

Diagram Conventions

SETup[:ALL]:CONTinuous



SETup:ATXPower



SETup:CAPPower

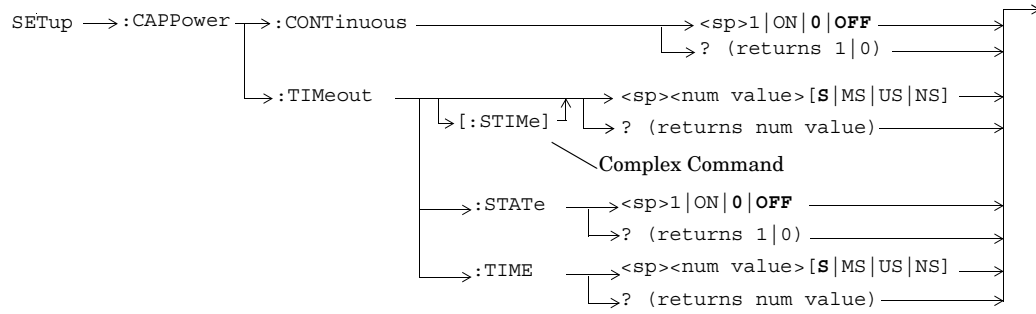
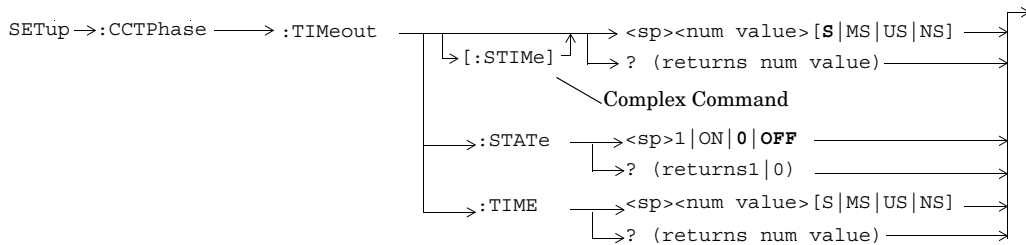
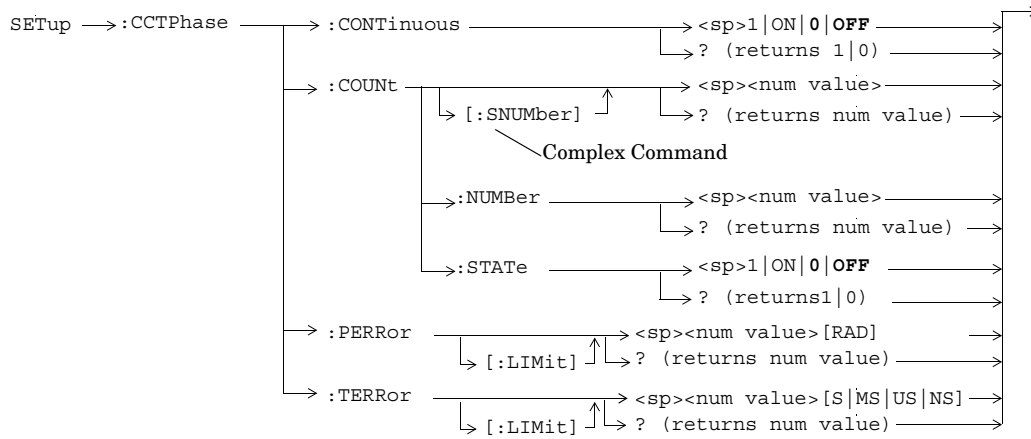

Diagram Conventions

SETup:CCTPhase



SETup:CFERror

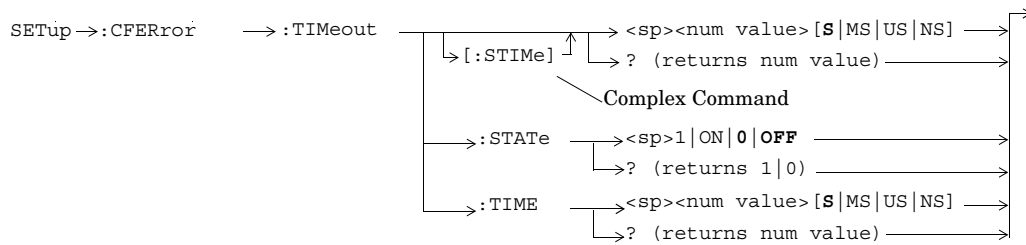
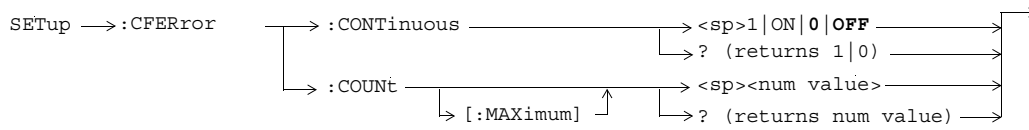
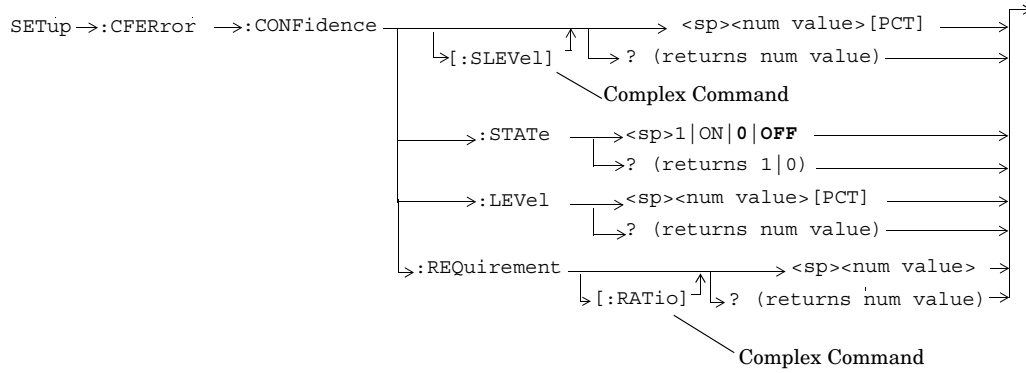
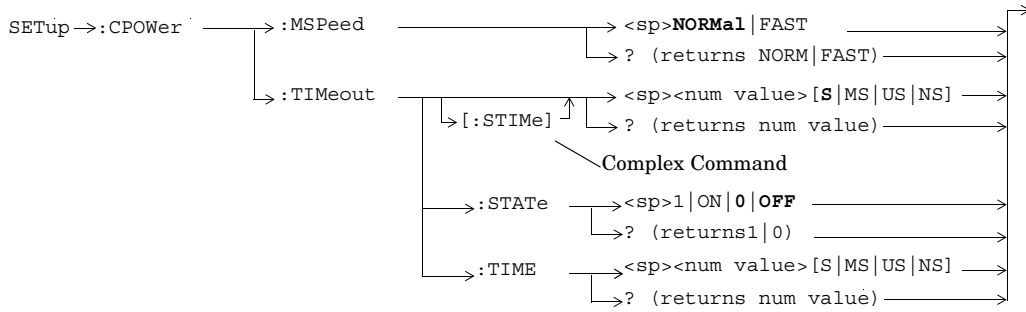
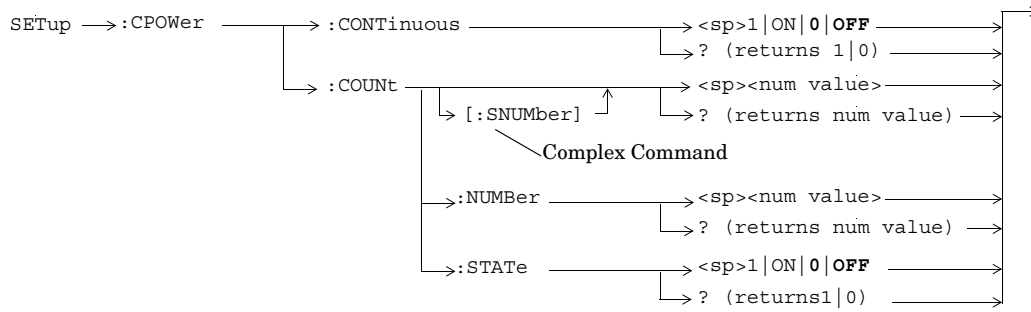

Diagram Conventions

SETup:CPOWER



SETup:CTXSpurious

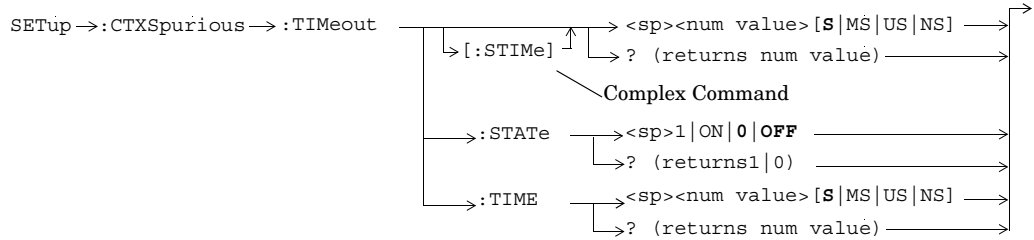
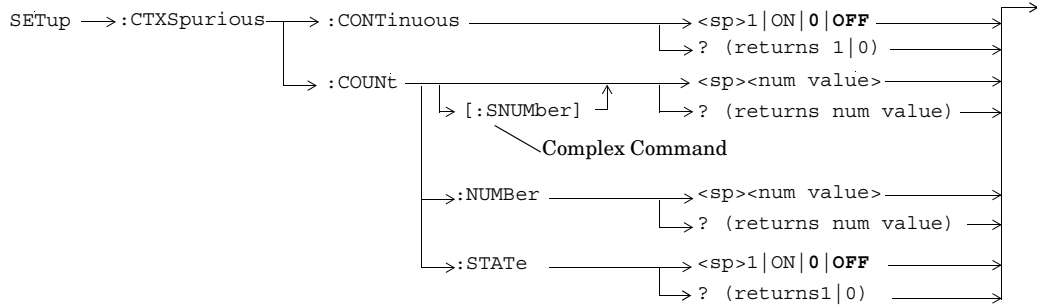
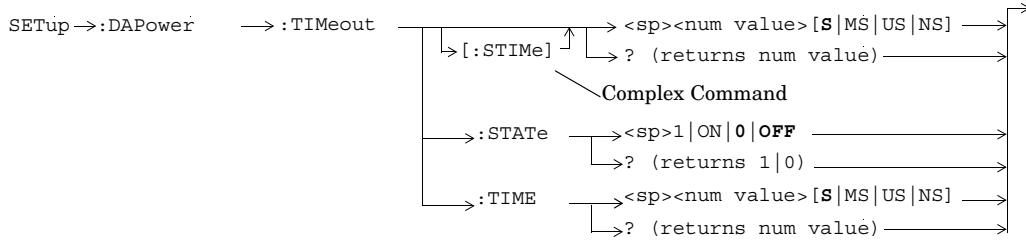
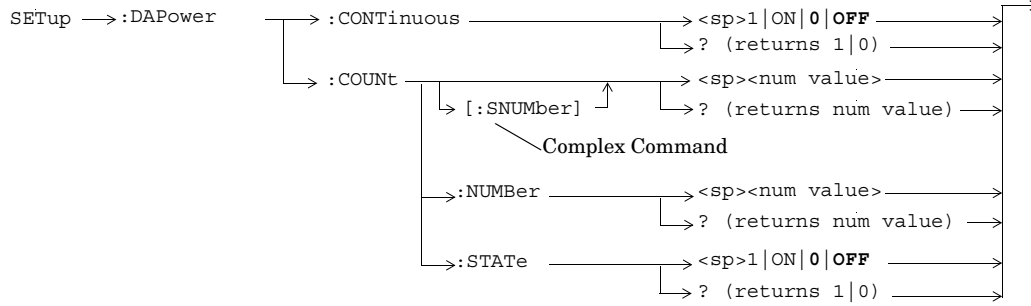

Diagram Conventions

SETup:DAPower



SETup:FM

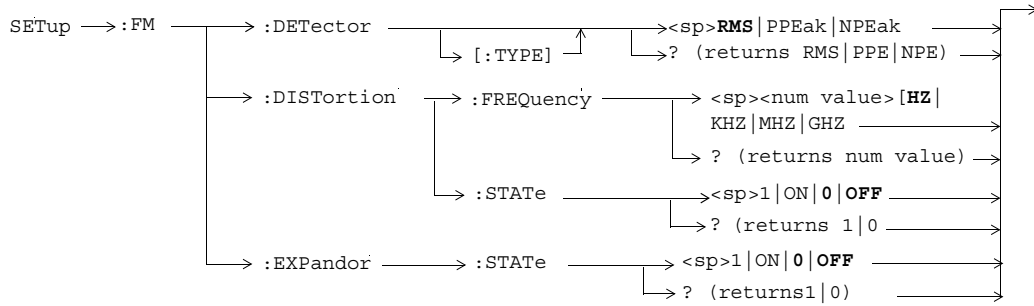
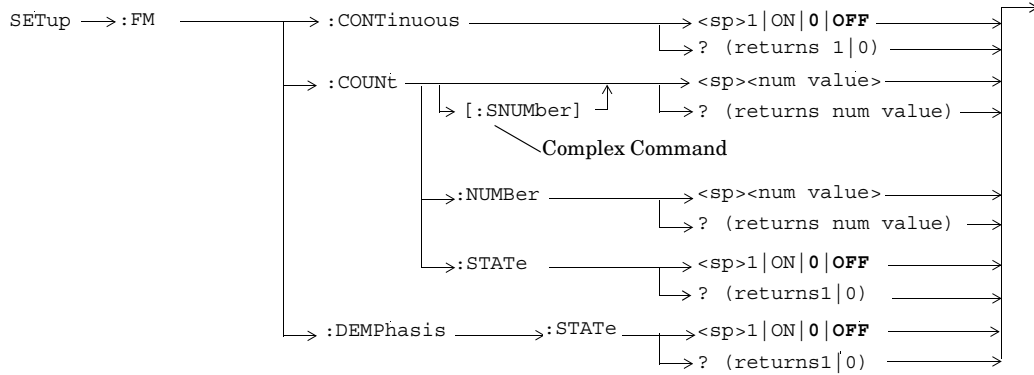
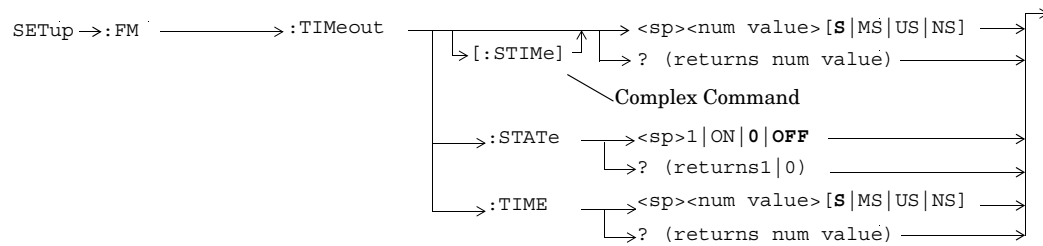
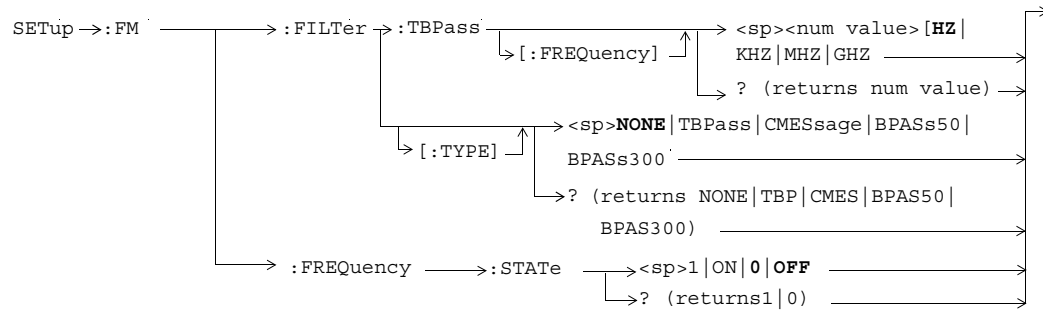

Diagram Conventions



SETup:FSTability

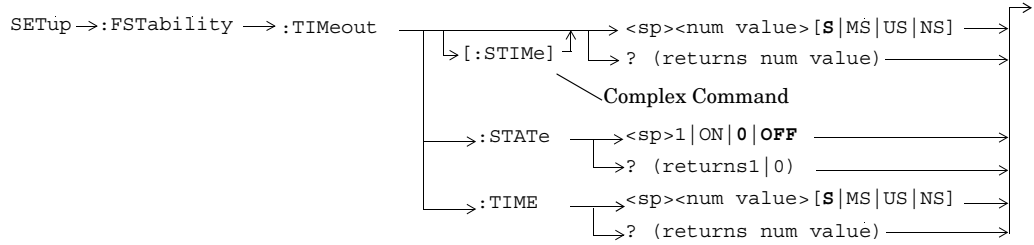
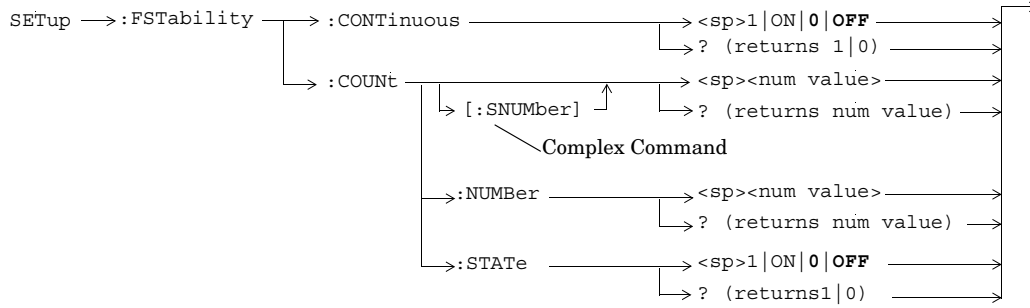
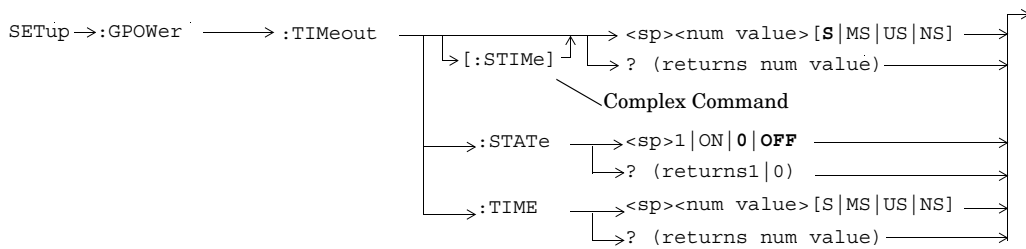
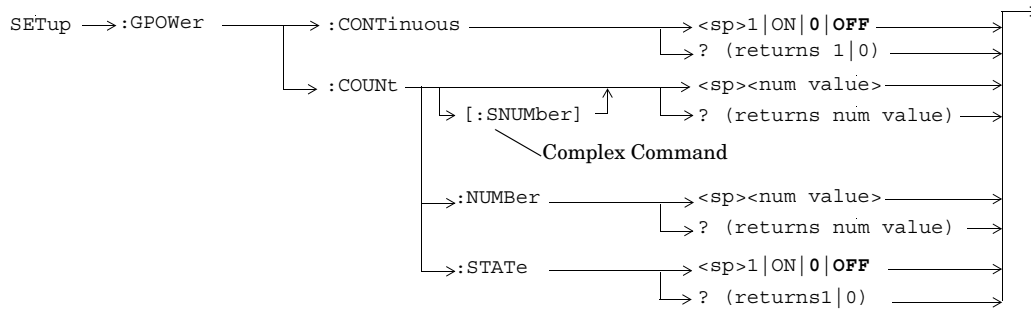
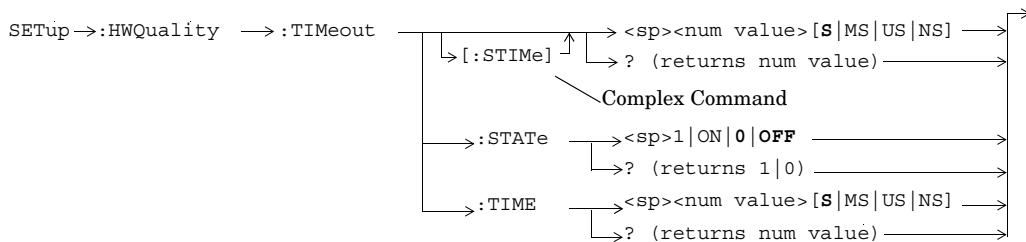

Diagram Conventions

SETup:GPOWER



SETup:HWQuality



SETup:SAudio

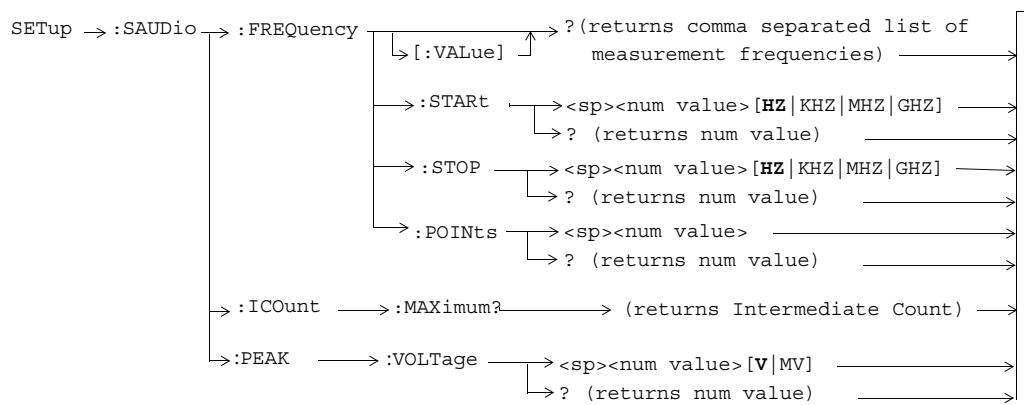
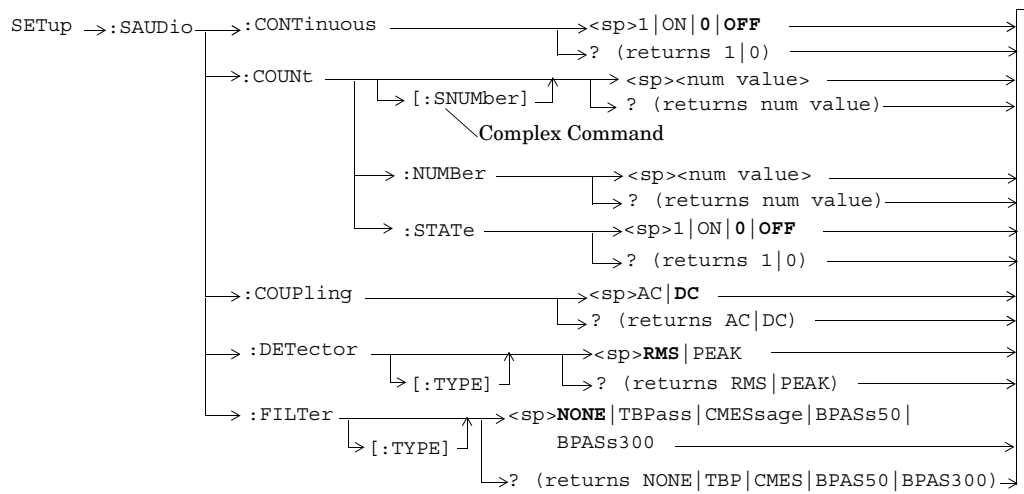
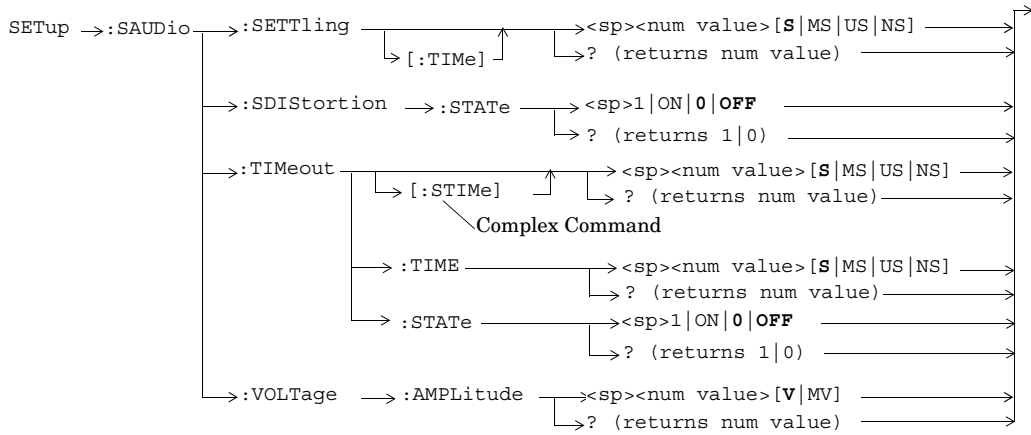
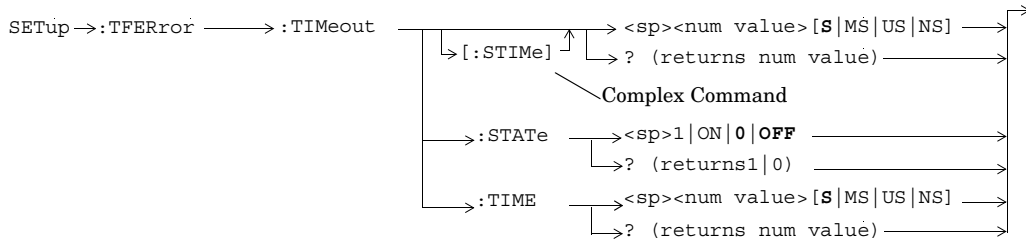
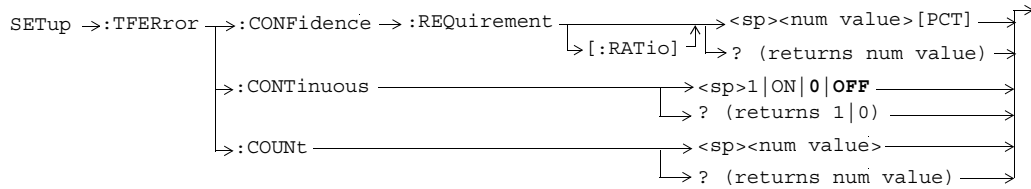

Diagram Conventions



SETup:TFERror



SETup:WQUality

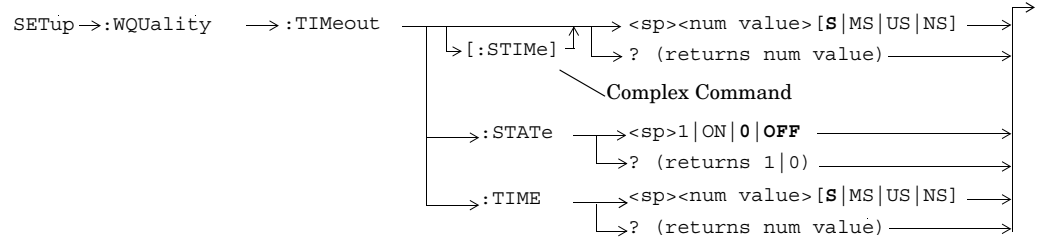
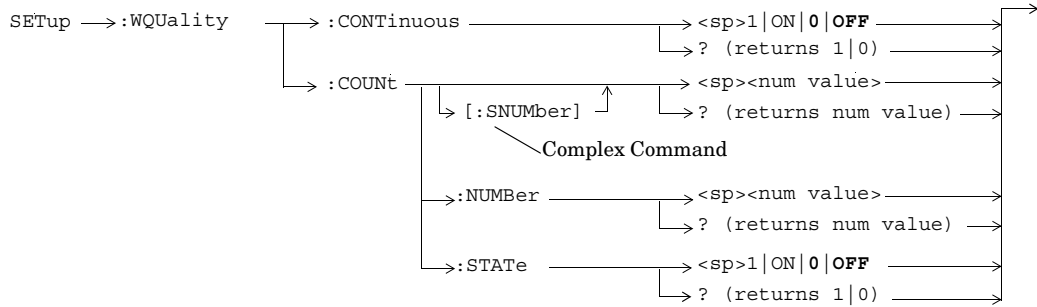
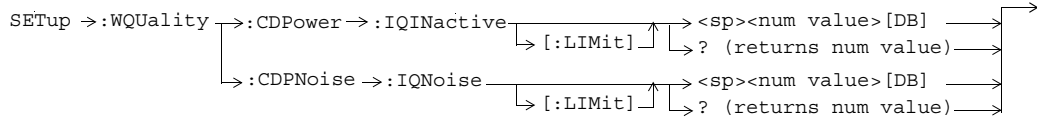

Diagram Conventions

STATUS:OPERation:

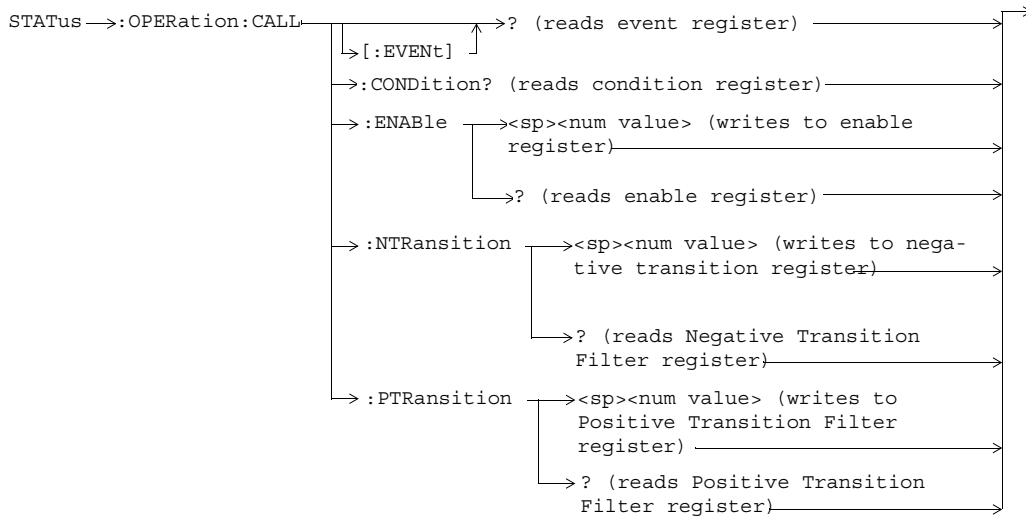
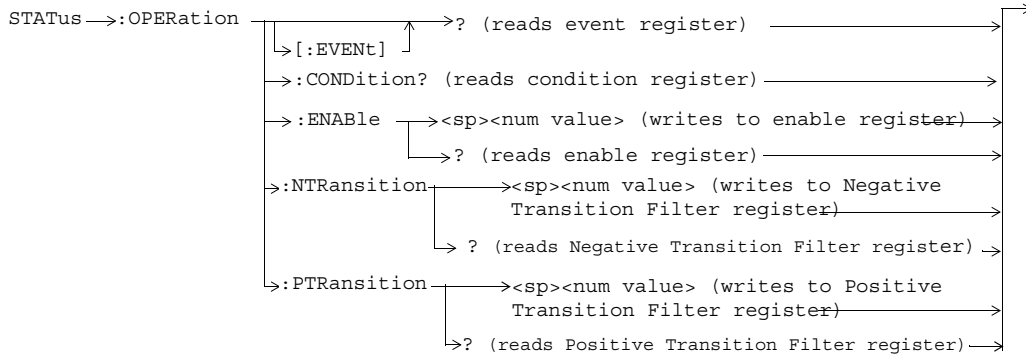

Diagram Conventions

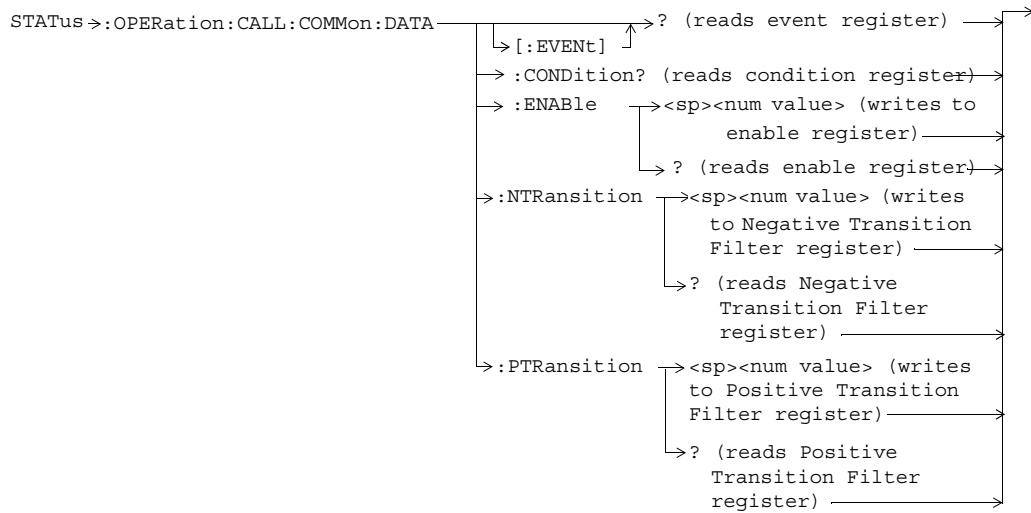
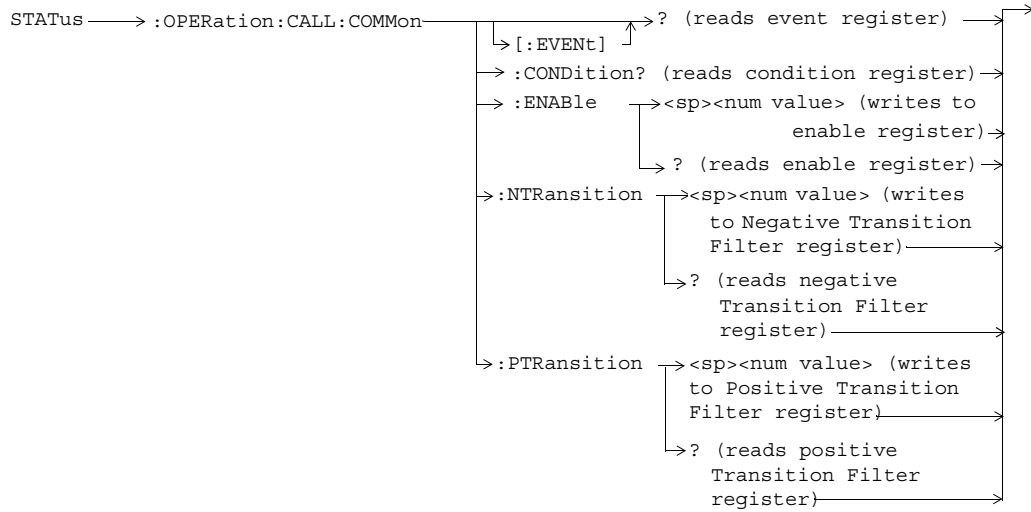

Diagram Conventions

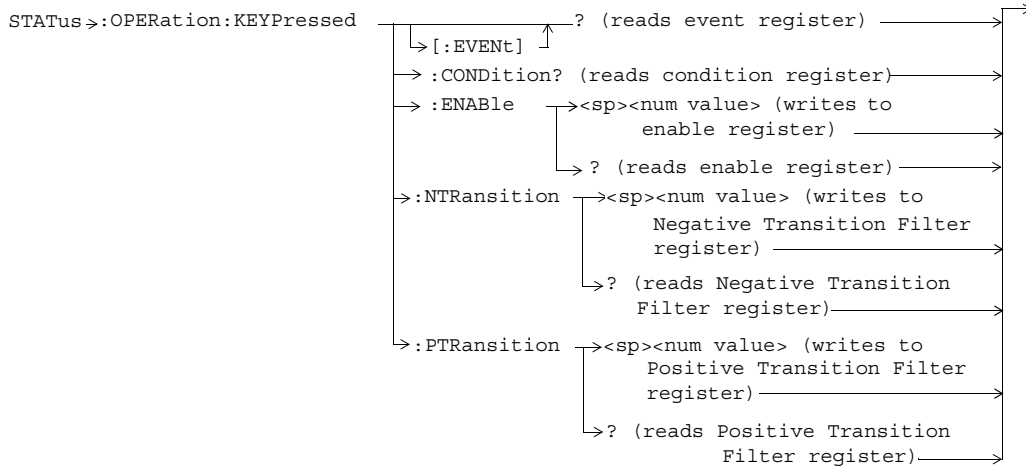
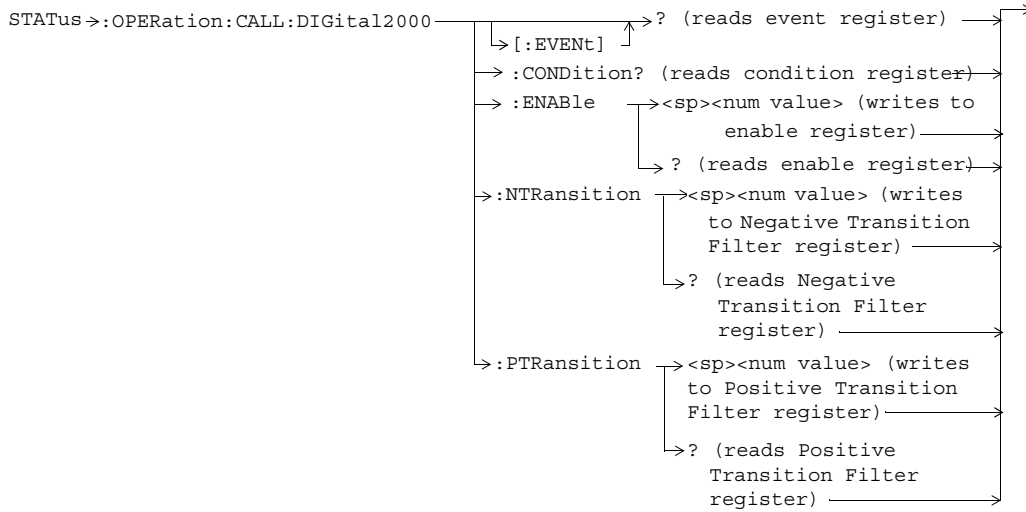

Diagram Conventions

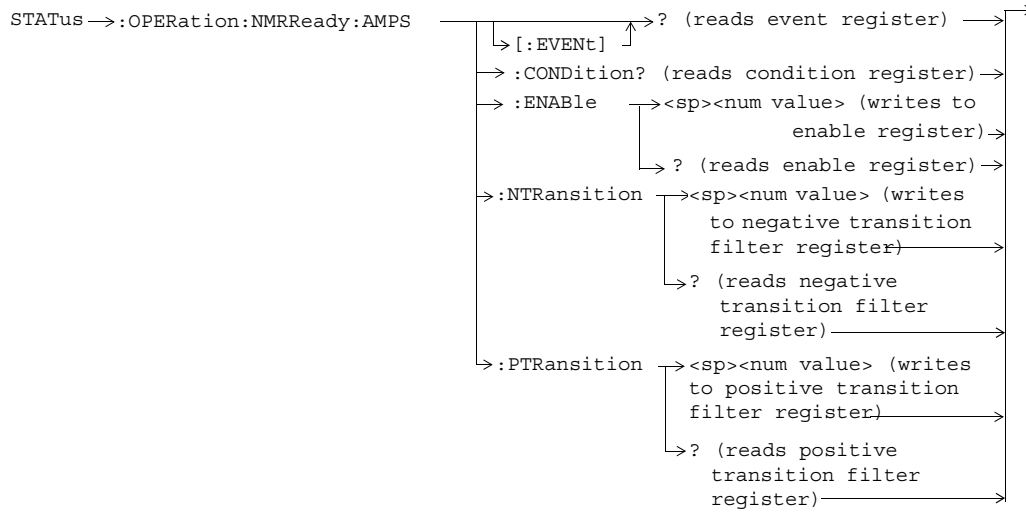
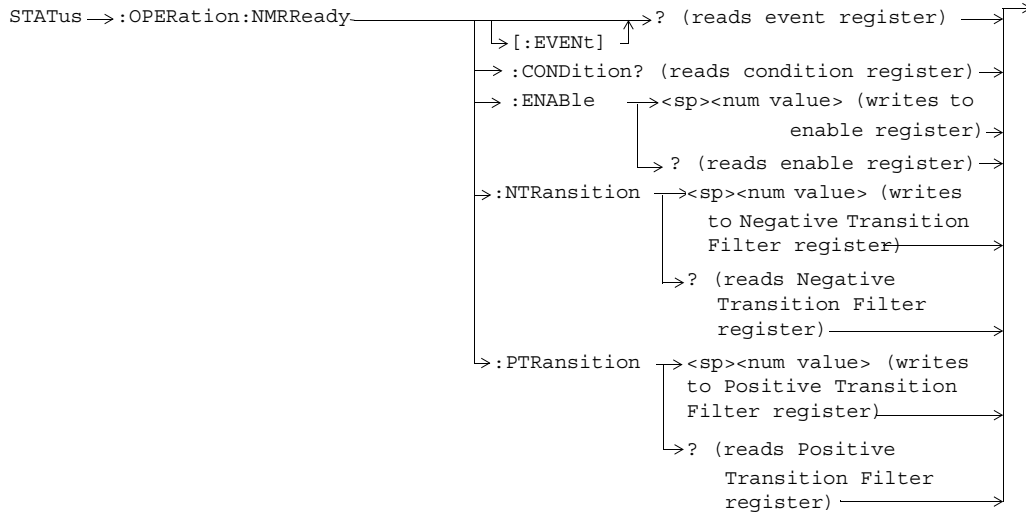

Diagram Conventions

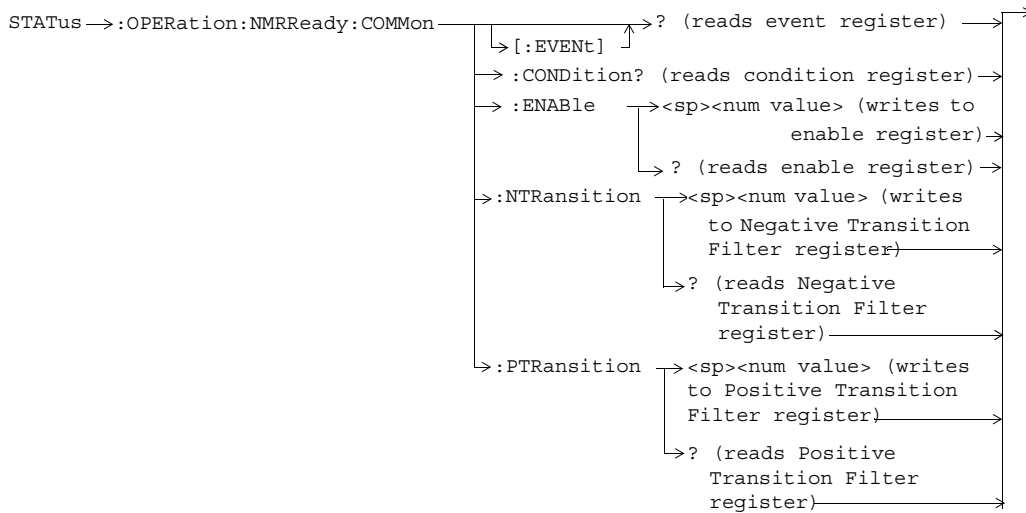
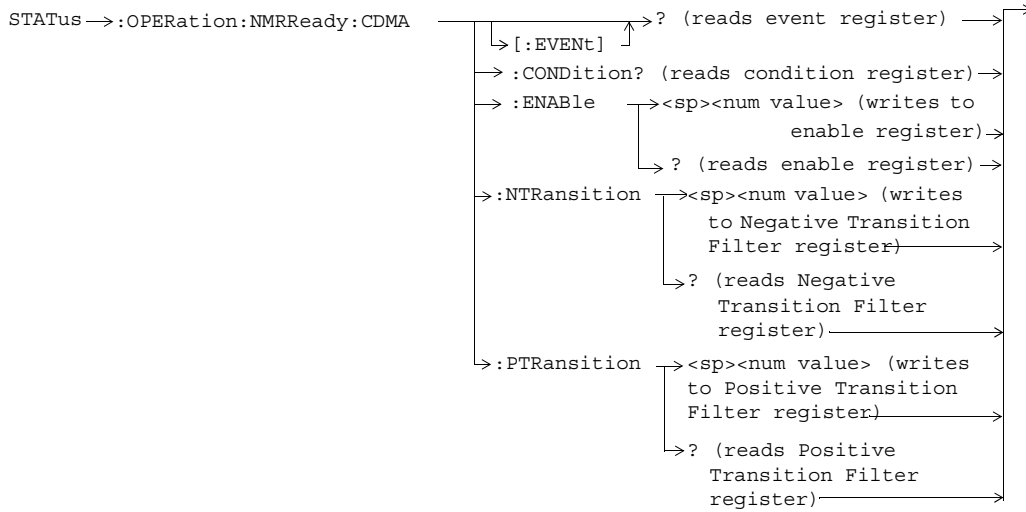

Diagram Conventions

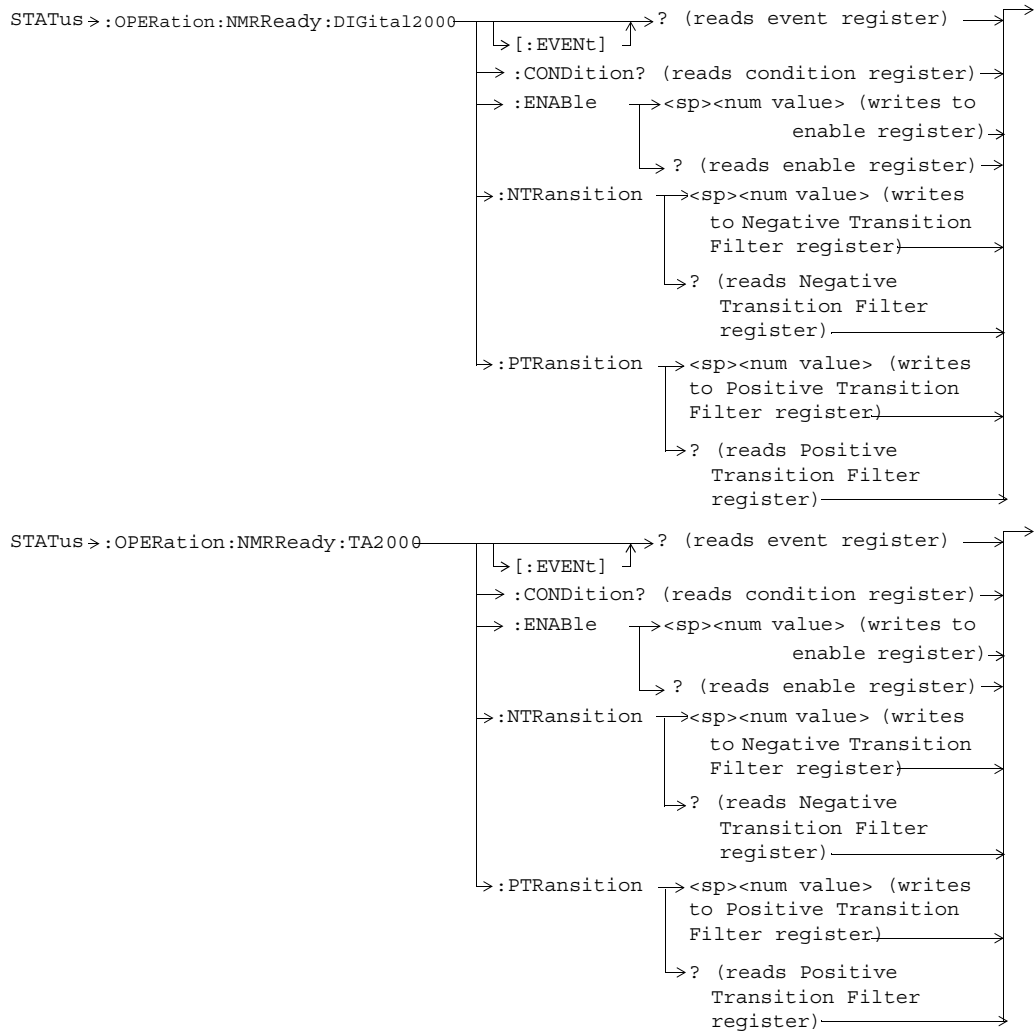
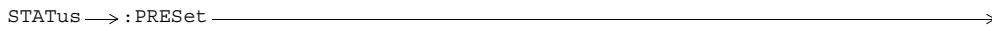

Diagram Conventions

STATUS:PRESet



STATUS:QUEStionable

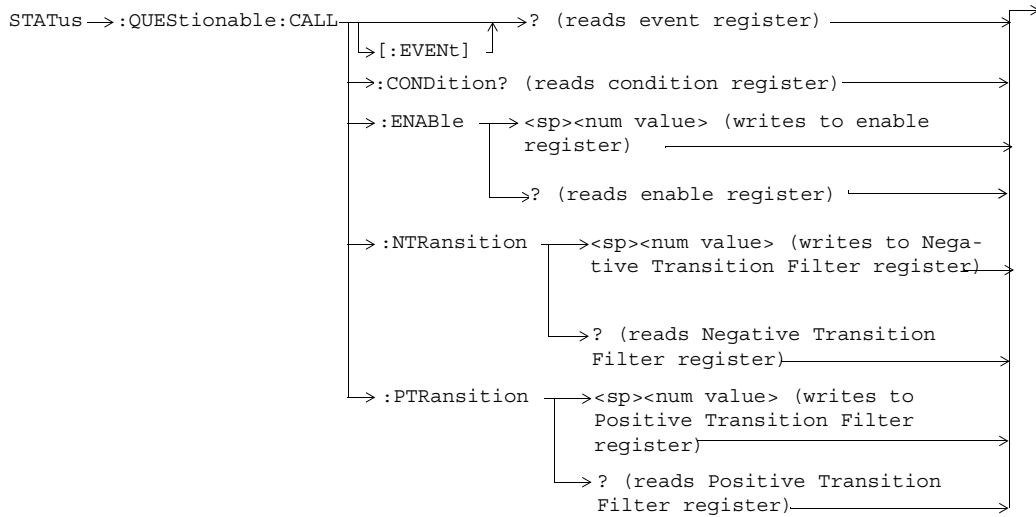
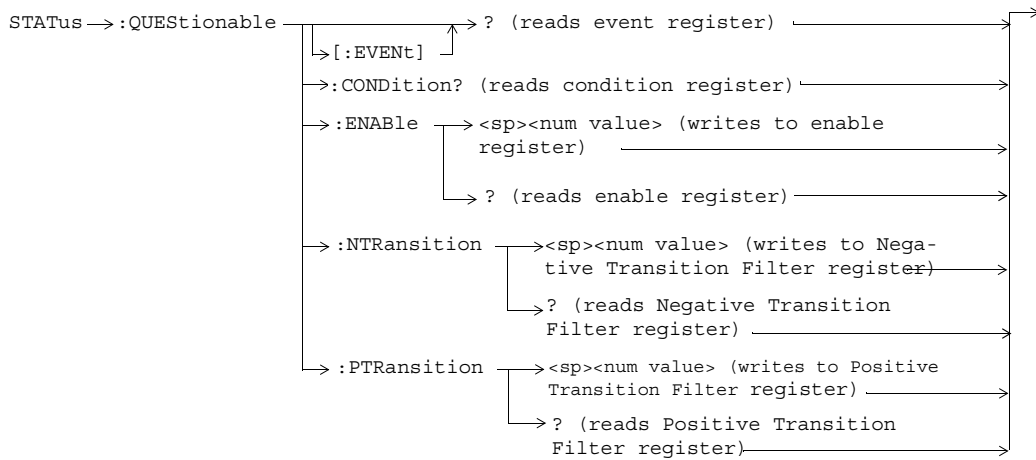

Diagram Conventions

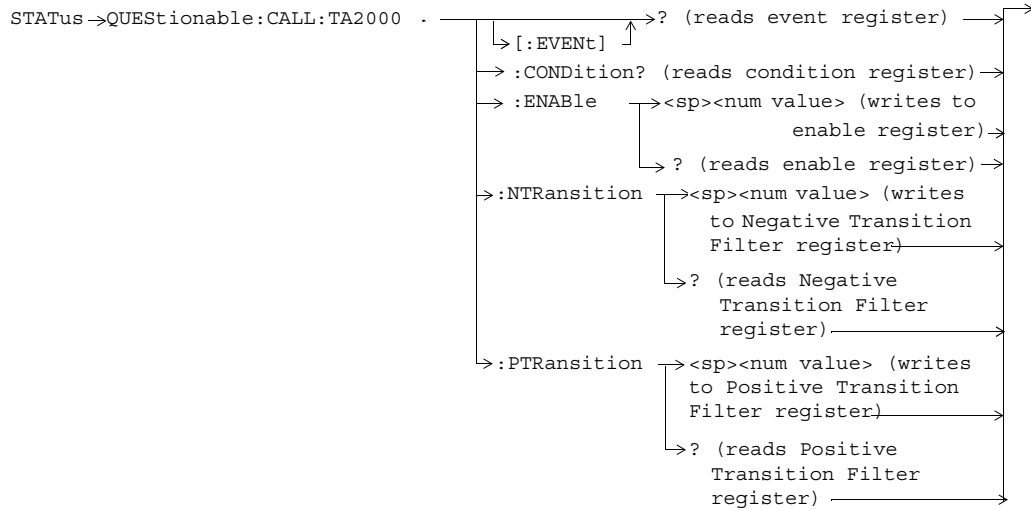
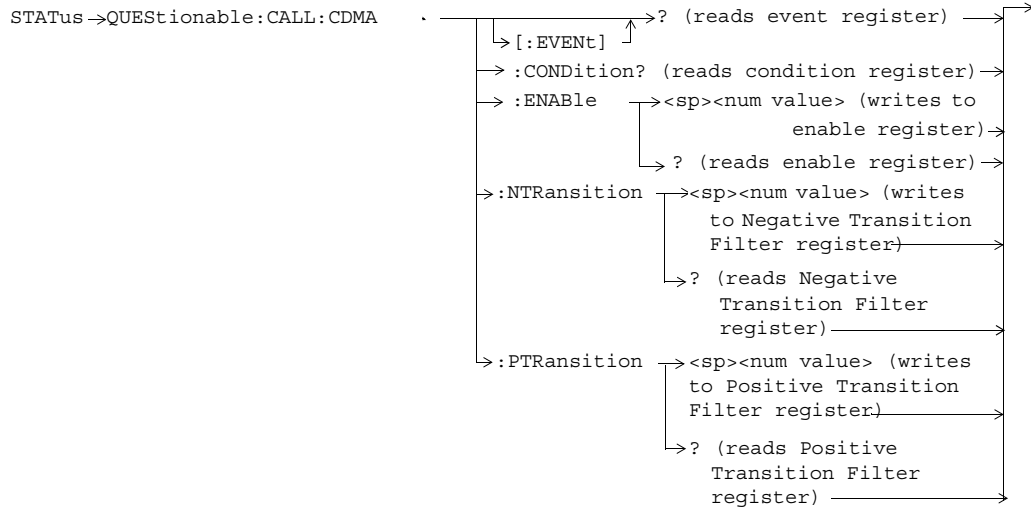

Diagram Conventions

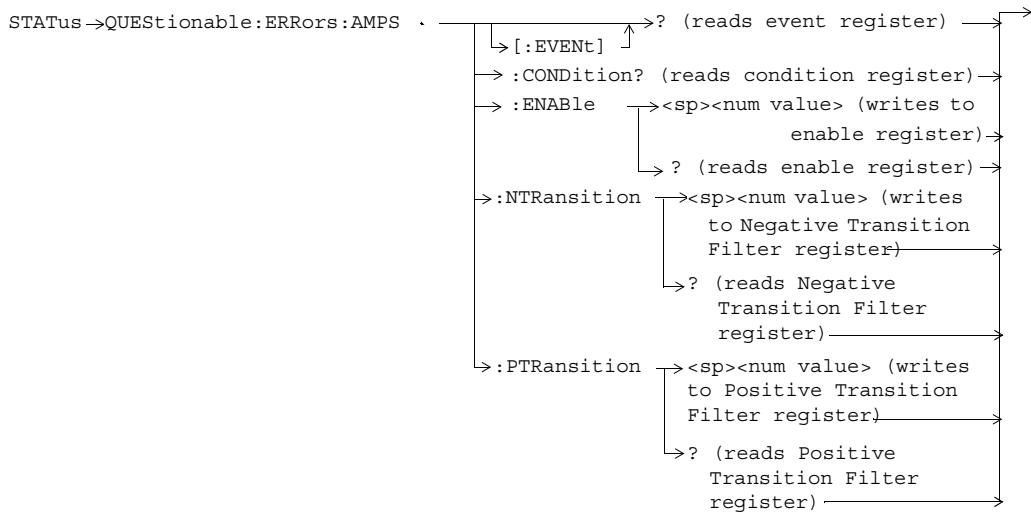
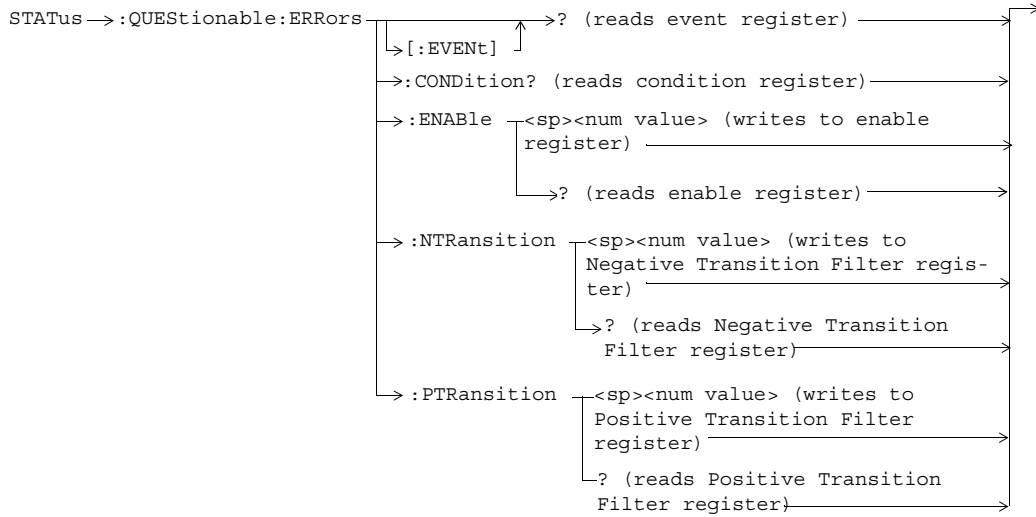

Diagram Conventions

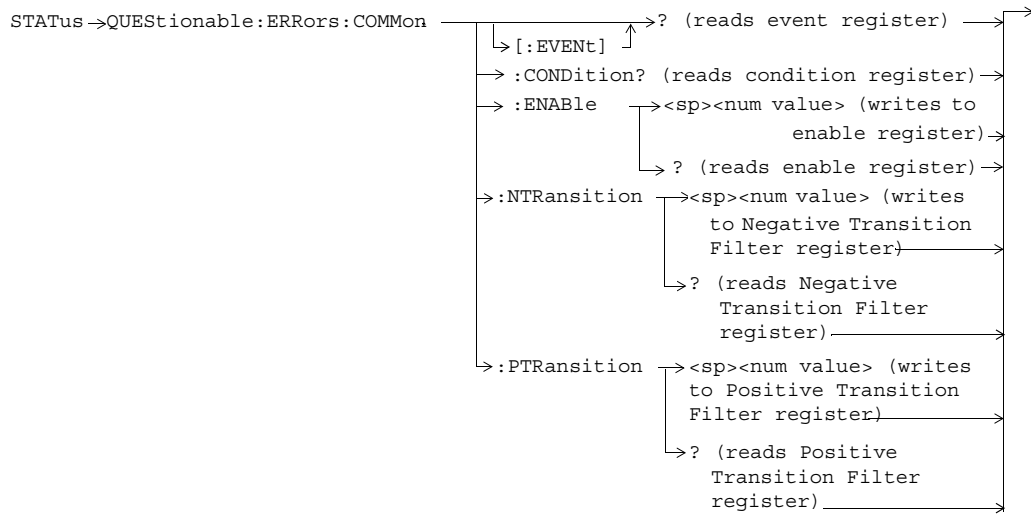
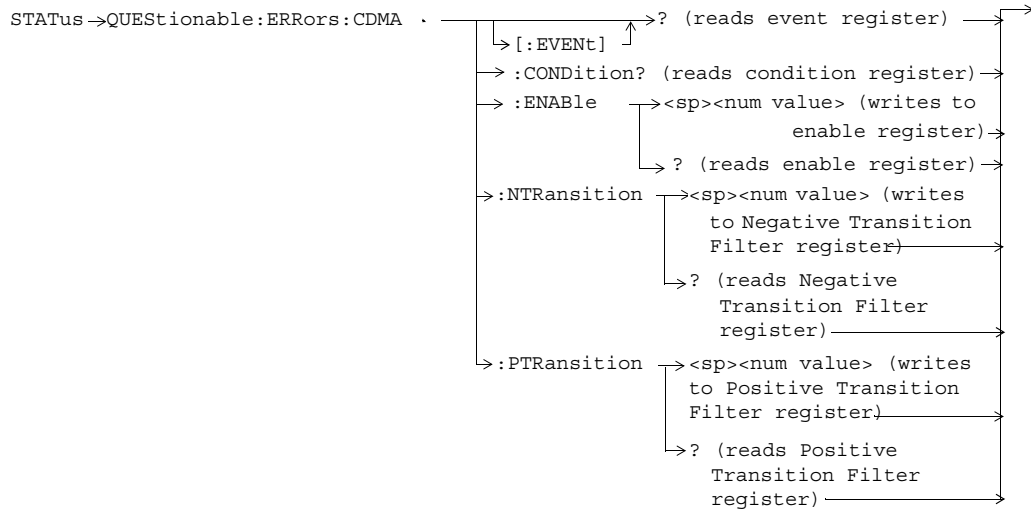

Diagram Conventions

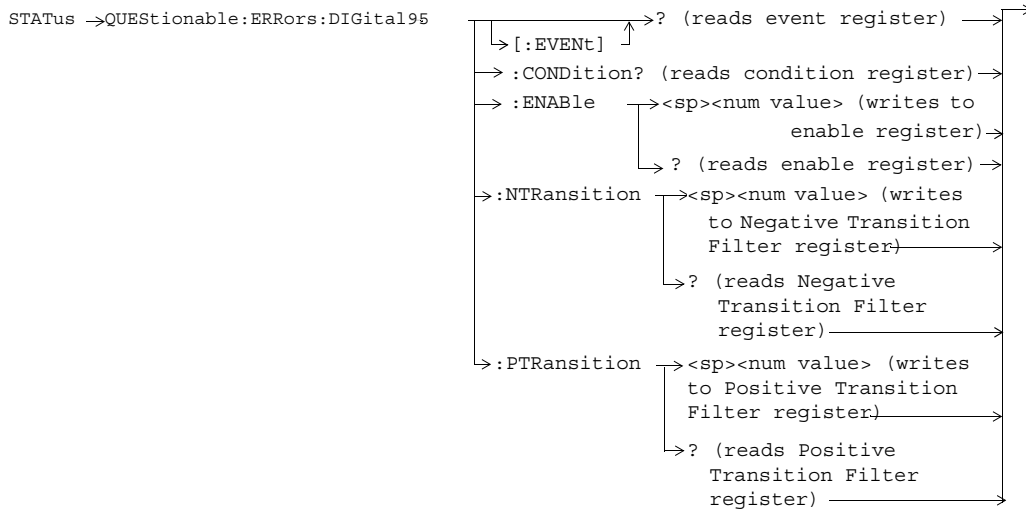
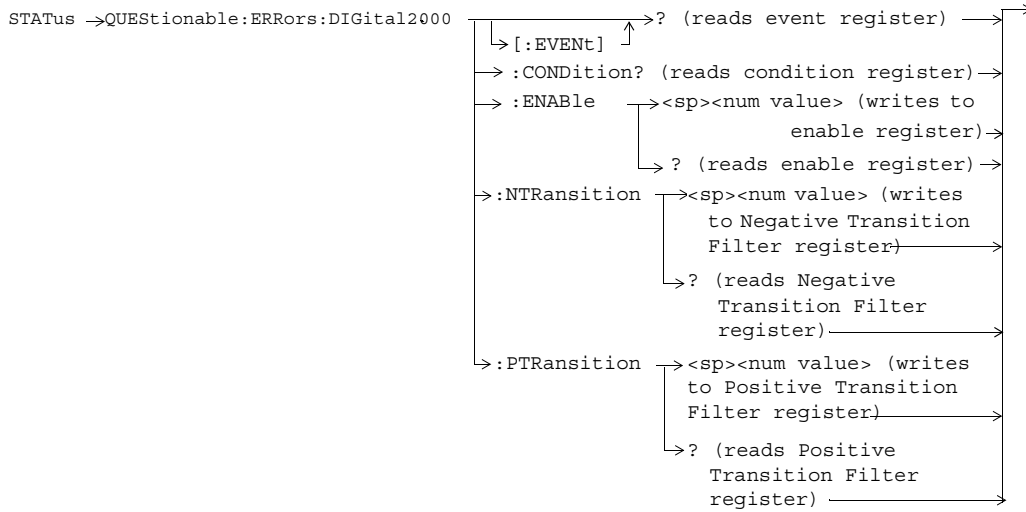

Diagram Conventions

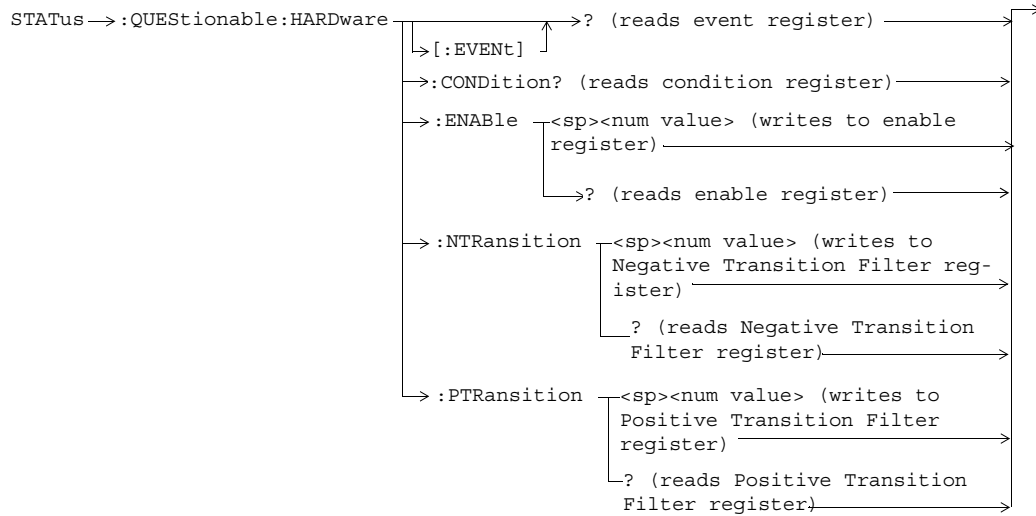
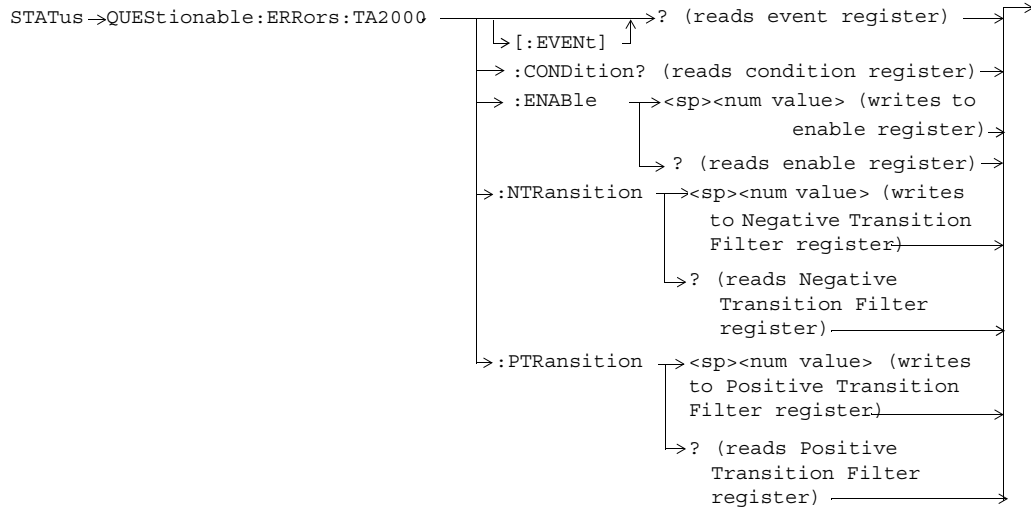

Diagram Conventions

Status Byte Register

***STB?**

*STB? _____ ↘ ↙

NOTE The Status Byte Register can also be read with a serial poll. For example, the command “Status_byte = SPOLL(714)” would perform a serial poll of the Status Byte Register, returning and releasing RQS (bit 6).

Status Byte Register Bit Assignments

Bit Number	Binary Weighting	Label	Description
7	128	STATus: OPERation	Summarizes the STATus: OPERation Status Register, which fans out to the NMRReady and CALL Status Registers.
6	64	RQS (SRQ TRUE?)/Master Summary Status	RQS is read by a serial poll (SPOLL) Master Summary Status is read by a *STB? query - defined by IEEE 488.2
5	32	Standard Event Status Register	Summarizes the Standard Event Status Register
4	16	Message Available	SCPI - Defined
3	8	STATus: QUEStionable Status Register	Summary Message comes from the STATus: QUEStionable Status Register, which fans out to the CALL and HARDware Status Registers
2	4	Error/ Event Queue	SCPI - Defined
1	2	Reserved	
0	1	Reserved	

Standard Event Status Register

***ESR?**

*ESR? —————> Reads and clears the Std Event Status Register. —————>

***ESE?**

*ESE? —————> Reads the Std Event Status Register Enable Register —————>

***ESE**

*ESE —————> Writes to the Std Event Status Register Enable Register —————>

“Diagram Conventions” on page 7

Diagram Conventions

Standard Event Status Register Bit Assignment

Bit Number	Binary Weighting	Condition	Description
15	32768	Reserved by IEEE.	This bit will always be 0.
14	16384	Reserved by IEEE.	This bit will always be 0.
13	8192	Reserved by IEEE.	This bit will always be 0.
12	4096	Reserved by IEEE.	This bit will always be 0.
11	2048	Reserved by IEEE.	This bit will always be 0.
10	1024	Reserved by IEEE.	This bit will always be 0.
9	512	Reserved by IEEE.	This bit will always be 0.
8	256	Reserved by IEEE.	This bit will always be 0.
7	128	Power On	This bit is set to 1 if the power supply has been turned off and on since the last time this register was read or otherwise cleared. Defined in "IEEE Std. 488.2-1992", 11.5.1.1.2
6	64	Reserved for future use.	This bit will always be 0.
5	32	Command Error	This bit is set to 1 if the test set detects an error while trying to process a command. The following events cause a command error: <ul style="list-style-type: none"> • An IEEE 488.2 syntax error. The test set received a message that did not follow the syntax defined by the standard. • A semantic error. For example the test set received an incorrectly spelled command. • The test set received a group execution trigger (GET) inside a program message
4	16	Execution Error	This bit is set to 1 if the test set detects an error while trying to execute a command. The following events cause an execution error: <ul style="list-style-type: none"> • A <PROGRAM DATA> element received in a command is outside the legal range for the test set, or it is inconsistent with the operation of the test set. • The test set could not execute a valid command due to some test set hardware/firmware condition.
3	8	Device Dependent Error	This bit is set to 1 if a test set operation does not execute properly due to an internal condition (such as, overrange). This bit indicates that the error was not a command, query, or execution error.

Diagram Conventions

Bit Number	Binary Weighting	Condition	Description
2	4	Query Error	This bit is set to 1 if an error has occurred while trying to read the test set's output queue. The following events cause a query error: <ul style="list-style-type: none">• An attempt is made to read data from the output queue when no data is present or is pending.• Data in the output queue has been lost. An example of this would be an output queue overflow.
1	2	Reserved for future use.	This bit will always be 0.
0	1	Operation Complete	This bit is set to 1 when the test set has completed all pending operations and is ready to accept new commands. This bit is only generated in response to the *OPC IEEE 488.2 common command.

Diagram Conventions

SYSTEM:APPLICATION

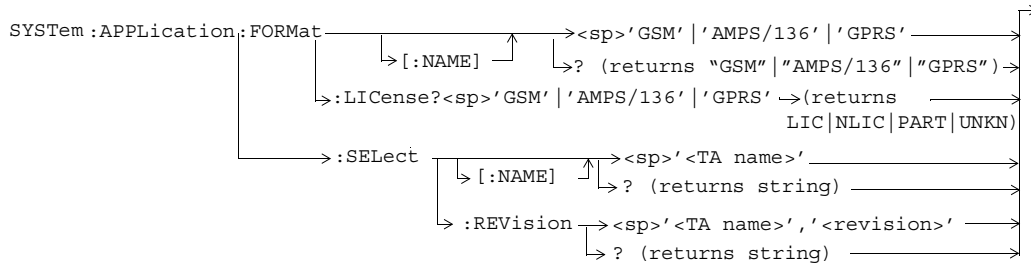
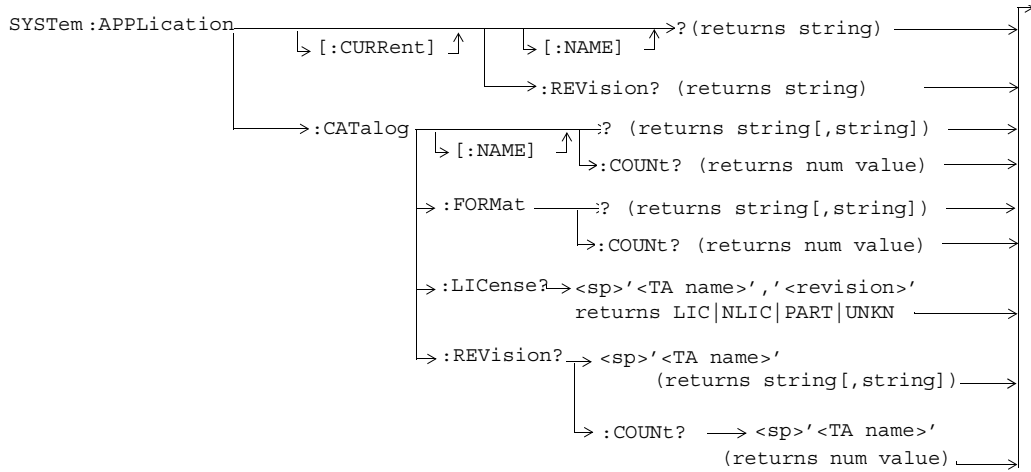

SYSTEM:BEEPER

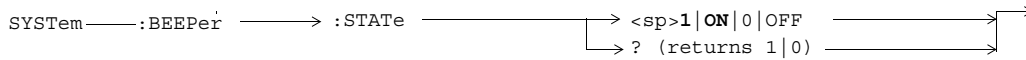

SYSTEM:CONFIGURE:INFORMATION:HARDWARE:VERBOSE?

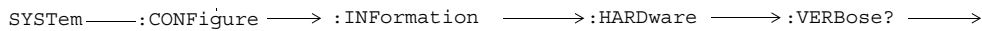

SYSTEM:COMMunicate

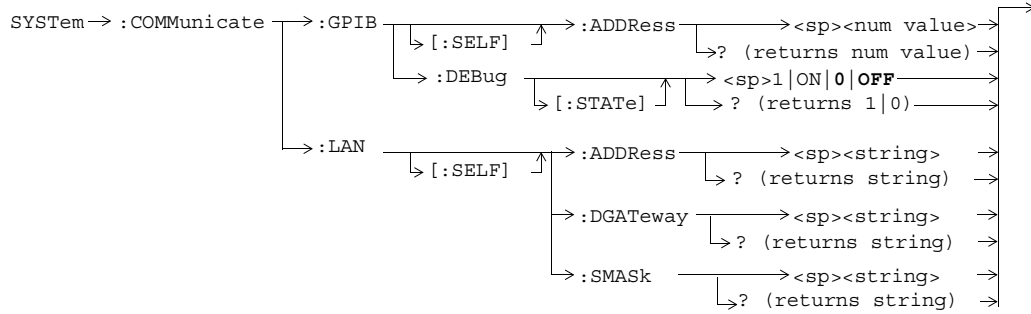

SYSTEM:CORRection

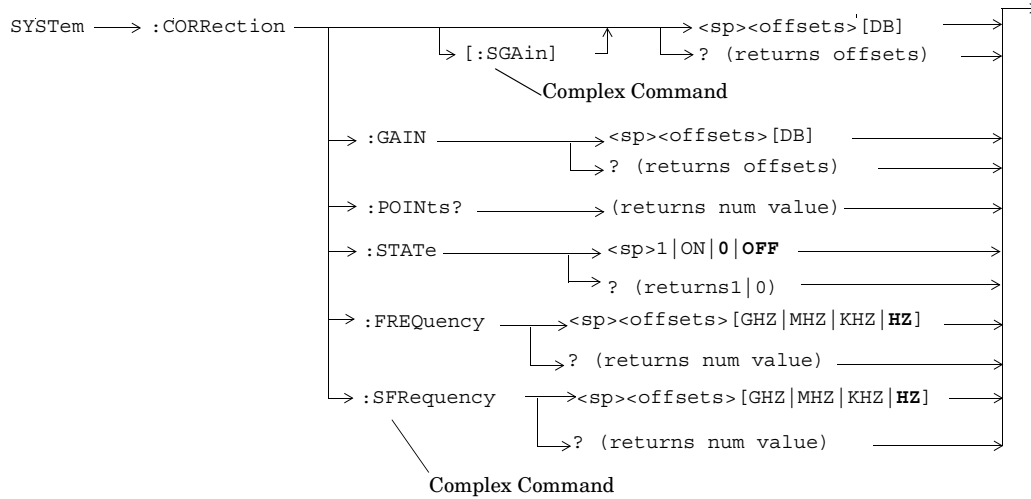
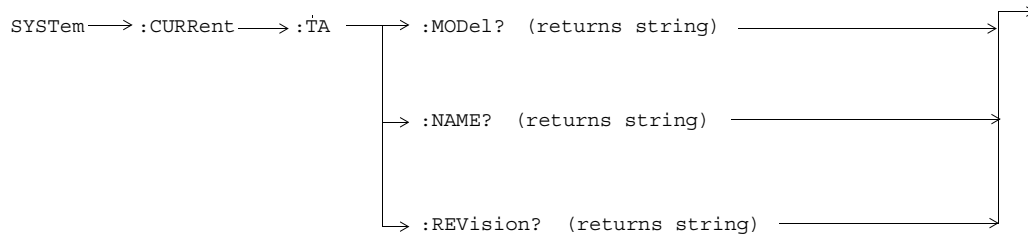
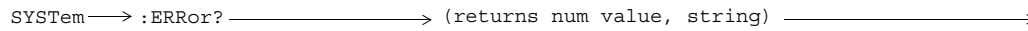

Diagram Conventions

SYSTEM:CURRENT:TA



SYSTEM:ERROR?



SYSTEM:MEASUREMENT:RESet

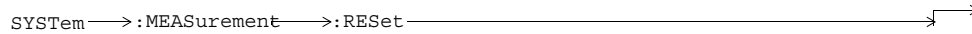

SYSTEM:PRESet

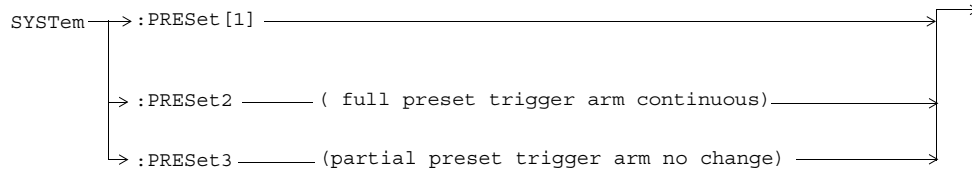

SYSTEM:ROSCillator

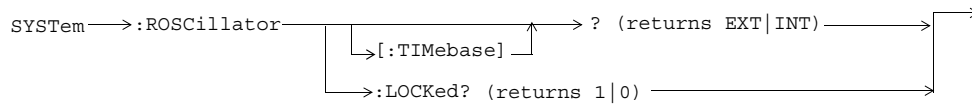

SYSTEM:SYNChronized

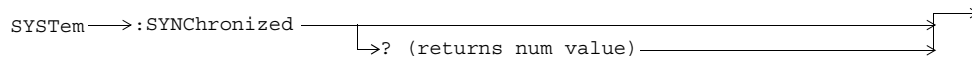

IEEE 488.2 Common Commands

Description

***CLS** The *CLS, clear status command, is defined in “IEEE Std 488.2-1992”, 10.3. This command will also clear and close the error message screen on the test set’s display.

***ESE** The *ESE, standard event status enable command, is defined in “IEEE Std 488.2-1992”, 10.10.

***ESE?** The *ESE?, standard event status enable query, is defined in “IEEE Std 488.2-1992”, 10.11.

***ESR?** The *ESR?, standard event status register query, is defined in “IEEE Std 488.2-1992”, 10.12.

***IDN?** The *IDN?, identification query, is defined in “IEEE Std 488.2-1992”, 10.14. *IDN? is used to retrieve information about the test set in ASCII format.

*IDN?, returns ASCII codes 32 through 126 excluding comma and semicolon in four comma separated fields. Field 1 returns the manufacturer, field 2 returns the instrument model number, field 3 returns the serial number, field 4 returns 0.

***OPC** The *OPC, operation complete command, is defined in “IEEE 488.2-1992”, 10.18. *OPC causes the test set to continuously sense the No Operation Pending flag. When the No Operation Pending flag becomes TRUE, the OPC event bit in the standard event status register (ESR) is set to indicate that the state of all pending operations is completed. The *OPC common command is not recommended for use as an overlapped command.

***OPC?** The *OPC?, operation complete query, is defined in “IEEE Std 488.2-1992”, 10.19. The *OPC? query allows synchronization between the controller and the test set using either the message available (MAV) bit in the status byte, or a read of the output OPC?. The *OPC? query does not effect the OPC event bit in the Standard Event Status Register (ESR). The *OPC? common command is not recommended for use as an overlapped command.

***OPT?** The *OPT?, option identification query, is defined in “IEEE Std 488.2-1992”, 10.20. Each option will have a unique name, that name will be returned with the query.

***RST** The *RST, full preset command, is defined in “IEEE Std 488.2-1992”, 10.32. *RST is the recommended command when performing a full preset on the test set. A *RST restores the majority of settings to their default values.

- *RST sets trigger arm to single
- PRESet2 sets trigger arm to continuous

Diagram Conventions

***SRE** The *SRE, service request enable command, is defined in “IEEE Std 488.2-1992”, 10.34. The parameter range for this command is 0 through 255.

***SRE?** The *SRE?, service request enable query, is defined in “IEEE Std 488.2-1992”, 10.35. Values returned by this query range from 0 through 255.

***STB?** The *STB?, read status byte query, is defined in “IEEE Std 488.2-1992”, 10.36. Values returned by this query range from 0 through 255.

***WAI** The *WAI, wait-to-continue command, is defined in “IEEE Std 488.2-1992”, 10.39. The *WAI command prevents the test set from executing any further commands or queries until all pending operation flags are false. The *WAI common command is not recommended for use as an overlapped command.

Index

To find a syntax equivalent for a field on the Test Set's display.

1. Find the field name on the Test Set's display.

2. Look up the name in the alphabetical listing.

3. Turn to the page indicated.

Numerics

-0.885 MHz Offset, 45, 55
0.885 MHz Offset, 45, 55
-1.98 MHz Offset, 45, 55
1.98 MHz Offset, 45, 55
100 Hz BW BPF Center Frequency, 68
audio analyzer, 59

A

ACC Channel, 10
Access Probe Power, 43, 55
Active Cell Status, 14
Amplitude, 9
Analog MS TX Level, 17, 34
Analog Transmit Power, 43
Minimum, Maximum, Average, Std Dev, 43
Analog Voice Channel, 34
ATXP
See also Analog Transmit Power
Audio Analyzer Setup
Measurement Timeout, 59
SINAD/Distortion Fundamental Frequency, 59
SINAD/Distortion State, 59
Audio Frequency, 41
Audio Generator, 9
Audio Generator Coupling, 71
Audio Level, 42, 55
AVC Channel, 31
AWGN Power, 12
AWGN Power (dBm/1.23 MHz)
Current Level, 34
Desired Level, 12

B

Band Class, 17
Band Pass Filter Frequency
FM, 68
Beeper State, 90

C

Cal. first IQ mod, 10
Cal. second IQ mod, 10
Carrier Feedthrough, 51
Handoff Waveform Quality, 48
cdg escape mode
, 15
Cell Band, 12
Cell MCC, 17
Cell MNC, 17
Cell Power, 26
Cell Power (dBm/1.23 MHz)
Current Level, 35
Channel Power, 45, 55
Clear MS & Capability Info, 20
Code Channel Time/Phase Error,
44
Code Domain Power, 51
Code Domain Power + Noise, 52
Confidence, 44
Frame Error Rate, 55
TDSO Frame Error Rate, 50
Convolutional Encoder Supported
F-SCH, 19
R-SCH, 20
Coupling, 9
Curr F-QPCH Level (Rel to Pilot),
35
Curr F-QPCH State, 35

D

Data Rate, 30
DCCH Frame Size, 18
DCCH Supported, 18
debug feature, 8
De-Emphasis State
audio analyzer, 59
FM, 67
Default Gateway, 91
Desired Level (dB), 22
Detector Type, 71
Peak -, 67
Peak (audio analyzer), 59
Peak +, 67
RMS (audio analyzer), 59
RMS (FM), 67
Deviation
FM, 55
dialed number
mobile station reported, 21
Digital Average Power, 45, 55
Display Brightness, 40
Display Mode, 40
Distortion
audio, 41
Audio Analyzer, 55
FM, 46, 55

Swept Audio, 49
Distortion (%)
Minimum, Maximum, Average,
46
Distortion Fundamental
Frequency, 67
Distortion State, 67

E

Enhanced RC support, 22
Escape Mode, 15
ESN (Hex), 14
EVM, 51
Execute Handoff, 31
Expander Reference Level
audio analyzer, 59
Expander State, 67
Expected CW Power, 57
Expected Peak Voltage, 71
Ext FM State, 16
External Trigger Type, 40

F

F-DCCH Radio Configurations,
18
FCH Fms Frames Supported, 18
FCH Service Option Setup, 33
FCH Supported, 18
FER, 44
Frame Error Rate, 55
TDSO Frame Error Rate, 50
FER Requirement, 63
F-FCH Radio Configurations, 18
F-FCH/Traffic
Current Level (dB), 35
F-FCH/Traffic Walsh Code, 39
Filter Type, 71
100 Hz BW BPF (audio
analyzer), 59
100 Hz BW BPF (FM), 68
300 Hz to 15 kHz (audio
analyzer), 59
300 to 15 k (FM), 68
50 Hz to 15 kHz (audio
analyzer), 59
50 to 15 k (FM), 68
C-Message (audio analyzer), 59
C-Message (FM), 68
None (audio analyzer), 59
None (FM), 68
FM Dev (kHz) RMS
Minimum, Maximum, Average,
46
FM Deviation, 46
F-OCNS Walsh Code, 22
F-Paging
Current Level (dB), 35

Index

- F-Pilot
 - Current Level (dB), 35
 - F-Pilot Level, 25
 - F-QPCH
 - Current Level (dB), 35
 - F-QPCH Desired Level (dB), 28
 - F-QPCH Indicator Bits, 14
 - F-QPCH Relative Level, 28
 - F-QPCH State, 28
 - Frame Count
 - TDSO Frame Error Rate, 72
 - Frame Error Count, 44, 55
 - Frame Error Rate, 44, 55
 - Frames Tested, 44, 55
 - Frequency, 9
 - Audio Analyzer, 55
 - Frequency Stability, 47, 55
 - Frequency (MHz)
 - amplitude offset, 91
 - Frequency Error, 51
 - Frequency Stability, 47
 - Handoff Waveform Quality, 48
 - Frequency Modulation, 46
 - Distortion, 46
 - FM Deviation, 46
 - integrity, 46
 - intermediate count, 46
 - Modulation Frequency, 46
 - Frequency Modulation Setup
 - 100 Hz BW BPF Center
 - Frequency, 68
 - De-Emphasis State, 67
 - Detector Type, 67
 - Distortion Fundamental
 - Frequency, 67
 - Distortion State, 67
 - Expandor State, 67
 - Filter Type, 68
 - Measurement Timeout, 68
 - Multi-Measurement Count, 67
 - Trigger Arm, 67
 - Frequency Stability, 47
- F-SCH
 - Current Level (dB), 35
 - F-SCH Desired Level (dB), 30
 - F-SCH Supported, 19
 - F-Sync
 - Current Level (dB), 35
 - F-Sync Level, 38
 - FULL (preset) key, 80
- G**
- Gated Power, 48
 - GPIO Address, 91
- H**
- Handoff, 17
 - Handoff Channel, 31
 - Handoff System Type, 32
 - Handoff Waveform Quality, 48
- I**
- Initial Power, 11
 - Instrument Information
 - Test Application, 92
 - Int FM Dev, 16
 - Int FM Freq, 16
 - integrity
 - FM, 46
 - intermediate count
 - FM, 46
- L**
- LAN IP Address, 91
 - Last Calibration, 10
- M**
- Magnitude Error, 51
 - Handoff Waveform Quality, 48
 - Maskable Message Display State, 40, 91
 - Max EIRP, 14
 - Max Request Seq, 11
 - Max Response Seq, 11
 - Maximum Frame Count, 63
 - MCC
 - mobile station reported, 21
 - Meas Frequency, 57
 - Measurement Timeout
 - Analog Transmit Power, 60
 - audio analyzer, 59
 - Channel Power, 62, 64
 - Digital Average Power, 61, 66
 - FM, 68
 - Frame Error Rate, 63
 - Frequency Stability, 69
 - Gated Power, 70
 - TDSO Frame Error Rate, 72
 - Waveform Quality + Code
 - Domain, 73
 - Message Log, 92
 - Min Power Control Step, 21
 - MIN1 (Hex)
 - mobile reported, 21
 - MIN2 (Hex)
 - mobile reported, 21
 - MNC
 - mobile station reported, 21
 - Modulation Frequency, 46
 - MS Operating Mode, 21
 - MS TX Level, 32
 - MSIN
 - mobile station reported, 21
- M**
- Multi-Measurement Count
 - Analog Transmit Power, 60
 - audio analyzer, 59
 - Channel Power, 62, 64
 - Digital Average Power, 66
 - FM, 67
 - Frequency Stability, 69
 - Gated Power, 70
 - Swept Audio, 71
 - TX Spurious Emissions, 65
 - Waveform Quality + Code
 - Domain, 73
- N**
- Network ID (NID), 22
 - Nominal Power, 11
 - Nominal Power Ext, 11
 - Number
 - amplitude offset, 91
 - Number of Points, 71
 - Number of Steps, 11
 - Number of Supported Channels
 - F-SCH, 19
 - R-SCH, 20
- O**
- OCNS
 - Current Level (dB), 35
 - Desired Level (dB), 22
 - Offset (dB)
 - amplitude offset, 91
 - Operating Mode
 - Active Cell, 23
 - AVC Test, 23
 - CW, 23
 - IS-2000 Test, 23
- P**
- Paging Data Rate, 24
 - Paging MCC, 24
 - Paging MNC, 24
 - Paging MSIN, 24
 - Paging Type, 24
 - Phase Error, 51
 - Handoff Waveform Quality, 48
 - Phase Limit, 62
 - PN Offset, 25
 - Power Class, 20
 - Power Step, 11
 - Preamble Size, 11
 - PRESET key, 80
 - programming, debug feature, 8
 - Protocol Rev, 27
 - Protocol Revision, 21
 - Pulse, 9
 - Pwr Ctrl Size, 13

Index

-
- Q**
QPCH Supported, 21
Query MS Capability Info, 18
- R**
Radio Config, 28
Radio Configurations
 F-SCH, 19
 R-SCH, 20
Rate Set 1 Max Data Rate
 F-SCH, convolutional encoder, 19
 F-SCH, Turbo, 19
 R-SCH, convolutional encoder, 20
 R-SCH, Turbo, 20
Rate Set 2 Max Data Rate
 F-SCH, convolutional encoder, 19
 F-SCH, turbo encoder, 19
 R-SCH, convolutional encoder, 20
 R-SCH, turbo encoder, 20
Rcvr Power Ctrl, 57
R-DCCH Radio Configurations, 18
Register Mobile, 29
Registration Period, 29
Registration Type, 22
Rev. License, 90
RF Gen Freq, 29
RF Gen Freq Ctrl, 14
RF IN/OUT Amplitude Offset State, 91
RF IN/OUT Amptd Offset, 91
RF IN/OUT Amptd Offset Setup, 91
Rho, 51
 Handoff Waveform Quality, 48
R-SCH Supported, 20
Rvs Link Freq, 57
Rvs Power Ctrl, 13
RX Blank Frames, 50
RX Good Frames, 50
- S**
SAT Color Code, 31, 34
SAT State, 11
SID, 32
SINAD, 42
 Audio Analyzer, 55
 Swept Audio, 49
SINAD/Distortion Fundamental Frequency, 59
 audio analyzer, 59
SINAD/Distortion State, 59
 audio analyzer, 59
 Slot Class, 22
 Slot Cycle Index, 22
 Start Frequency, 71
 Stop Frequency, 71
 Subnet Mask, 91
 Swept Audio, 49
 System ID (SID), 32
 System Type, 38
- T**
TDSO Frame Error Rate, 50
Test Application
 Setup, 90
 Test Application, Revision, License, 90
Test Application (instrument information), 92
test applications installed, 90
Time Based Registration State, 29
Time Error, 51
 Handoff Waveform Quality, 48
Time Limit, 62
Total RF Power (dBm/1.23 MHz)
 Current Level, 35
Traffic
 Current Level (dB), 35
Traffic Data Rate, 39
Transmission Mode, 20
Trigger Arm
 Analog Transmit Power, 60
 audio analyzer, 59
 Channel Power, 64
 Digital Average Power, 61, 66
 FM, 67
 Frame Error Rate, 63
 Frequency Stability, 69
 Gated Power, 70
 Swept Audio, 71
 TDSO Frame Error Rate, 72
 Waveform Quality + Code Domain, 73
Turbo Encoder Supported
 F-SCH, 19
 R-SCH, 20
TX Blank Frames, 50
TX Good Frames, 50
TX Spurious Emissions, 45, 55
- W**
Waveform Quality + Code Domain, 51